



We invented the popcorn machine  
**THEN JUST KEPT GOING!**

---

**176 MITTEL DRIVE, WOOD DALE, IL 60191**

---

## **CARAMEL CORN MIXER MODEL CMD 50**

**120/208 Volt,  
Single Phase, 60 Hz**

**120/240 Volt,  
Single Phase, 60 Hz**

**230 Volt,  
Single Phase, 50 Hz**

**400 Volt,      Three Phase, 50 Hz**



**READ and UNDERSTAND these operating and safety instructions before operating this popcorn machine**

## Table of Contents

I.	Safety Alert Symbol .....	3
II.	Safety First .....	3
III.	Introduction .....	3
IV.	Purpose of Manual .....	4
V.	Product Identification .....	4
VI.	Control Switches .....	4
VII.	Operating Instructions .....	4
VIII.	Sanitation Instructions .....	5

---

## I. SAFETY ALERT SYMBOL

The symbol shown is used to call your attention to instructions concerning your personal safety and the safety of others. Watch for this symbol. It points out important safety precautions. It means **ATTENTION! Become Alert! Your personal safety is involved!** Read the message that follows and be alert to the risk of personal injury or death.



---

## II. SAFETY FIRST



The information in this manual is essential for the safe installation and operation of your Cretors machine. The manual must be read and understood before installing, and operating the equipment, or equivalent training must be provided.



“The employer shall instruct each employee in the recognition and avoidance of unsafe conditions, as well as, the regulations applicable to his work environment and to control or eliminate any hazards or other exposure to illness or injury”. Ref.: 29 CFR 1926.20 (b)(4)(a)(2)



It is understood that safety rules within individual companies vary. If a conflict exists between the safety procedures contained in this manual and the rules of a using company, the more stringent rule should take precedence.

---

## III. INTRODUCTION

This manual is filled with time-saving and money-saving information regarding your Cretors machine. There is nothing more important than the safety aids and warnings that are throughout this document. The Safety Alert Symbol is used to identify topics of primary safety concern wherever they appear. Furthermore, a separate section has been included which deals exclusively with service and accident prevention.

If, after reviewing this manual, anything is unclear or technical problems are encountered, contact the distributor from whom you purchased your machine for assistance. If there are any additional questions, feel free to contact our Customer Service Department at the address and/or phone number listed on the last page of this manual. Always have the model and serial number of your machine available to assist in obtaining the correct information.

---

## IV. PURPOSE OF MANUAL

This instruction manual is intended to familiarize owners with the operation and safety procedures associated with your Cretors machine.

It is important that this manual be kept available to operating personnel.



A person who has not read and understood all operating and safety instructions is not qualified to operate the machine.

---

## V. PRODUCT IDENTIFICATION

CRETORS POPCORN MACHINE  
CAMEL CORN MIXER - CMD 50

---

## VI. CONTROL SWITCHES

KETTLE HEAT	-Turns the kettle heat On/Off.
MIXER	-Turns the stirrer blade motor On/Off.
DIGITAL CONTROLLER	-Displays and controls kettle temperature.

---

## VII. OPERATING INSTRUCTIONS

### A. To make a batch of Caramel Corn, proceed as follows:

1. Spray with Non-Stick the bottom, inside walls, mixing blades and stationary bars that are on the inside walls of the mixer. This serves to keep the mixer clean and also helps the caramel corn to separate into individual kernels after being coated.
2. Put the contents of 2 bags of Cretors Mix and 6oz. to 8oz of water into the mixer and follow the mix instructions.



**WARNING:** Under no circumstances should anyone insert any portion of their body or any object into the kettle when the auger or the bottom mixer is running. Rotation of the auger may cause serious injury including laceration, crushing injuries, amputations, and loss of life.

3. Turn on the switch marked HEAT. Turn on the switch marked MIXER briefly until the caramel mix is distributed uniformly over the bottom of the pan then turn off. It is recommended that the mixer is just bumped on then off occasionally to mix the product and NOT left on as this will lengthen your cook time.
4. Set the Temperature Controller on the side of the cabinet to 325°F. It may be necessary to adjust the temperature higher or lower to get the color and flavor you desire.
5. When the mix reaches the set point, the heat will automatically turn off which will also turn out the pilot light and sound the buzzer. At this time turn off the heat switch, turn

on the mixer switch (leave on) and add up to 2 measuring can (approximately 1 lb, 10oz.) of popped corn.

6. When the corn is well coated, spray with Non-Stick to separate.
7. Corn must be sprayed with Non-Stick in order for the individual kernels to separate.
8. When the corn appears to be separated and free in the mixer, dump the batch. Never run the mixer longer than necessary as this will break up the corn.
9. Turn the mixer motor off and dump the mixer by lifting up on the handle. Use the spatula supplied with the machine to assist in emptying the caramel corn from the mixer.
10. On succeeding batches, repeat steps 1 through 9.
11. On the last batch of the day, with the heat and mixers off, add at least 12oz. of water and place cover over the kettle to steam clean the inside of the kettle. **Caution: the kettle is still hot and steam will come out of top as you add the water and put the cover on.** Follow the CLEANING AND SANITATION procedure below.



**CAUTION:** Always turn off the HEAT switch before adding the popped corn. After the last batch is made and the mixer has cooled, spray Non-Stik into the mixer and leave it until next use. This will prevent any caramel from hardening underneath the blade hub causing it to stick and damage the motor drive.



Never leave heat on in mixer when machine is not in use. Be sure to turn off all switches when closing machine at night.

## B. Temperature Control

The temperature at which the elements will turn off and the buzzer will sound is determined by the setting of the Temperature Controller, P/N 14585-CMD or 14585-E-CMD. To raise or lower the temperature, push the up and down buttons on the front of the controller.

---

## VIII. SANITATION INSTRUCTIONS



Be certain the machine is turned off and power is unplugged before sanitizing this machine unless a specific cleaning procedure requires power to the machine. Failure to do so could result in injury or death.



Do not clean heated surfaces until they have been given sufficient time to cool. Failure to do so may result in serious burns or scalds.

The mixer should be thoroughly cleaned daily with warm water. When cleaning, do not fill the mixer with water more than two inches below the top of the mixer blades. The mixer heat may be used to heat the cleaning water. With the top on, allow the water to steam. This will clean the inside of the mixer kettle.

**CAUTION:** Do not boil the kettle dry. This will only make the cleanup more difficult.

Running the mixer blades after adding the water will speed up the cleaning operation. In the event any carbon has formed on the pan bottom, it may be easily removed by using C.K.C powder as directed.

The agitator blade can and should be removed and cleaned regularly. This is done by removing the one (or two) square head bolts holding the cap on. There is a key welded to the cap which aligns with the keyway on the shaft. Remove the bolt then lift the cap off. The blade can then be pulled straight up and off the hub.

Clean all parts thoroughly. Do not use any harsh abrasives or cleaning material. Pay particular attention to the interior of the blade center. Some times sugar will carbonize and/or build up on the interior of the blade center and create a tight fit on the pan center. (Normal clearance is 1/8" -- 3 mm). When this happens, syrup or water can 'wick-up' the narrow gap and leak down the clutch dog shaft and give the appearance that the kettle is leaking.

Clean the blade and under the blade, then replace the blade and align the blade keyway with the shaft keyway. Put the cap back on aligning the key with the keyway.

This manual is filled with time-saving and money-saving information regarding your Cretors machine. There is nothing, however, more important than the safety aids and warnings found throughout this document.

If you have any questions, contact your local distributor and if there are any additional questions, feel free to contact the Customer Service Department at C. Cretors and Company.

Additional copies of this manual can be obtained from C. Cretors and Company at the address listed below. Please provide model and serial number when requesting additional copies of this manual. There will be a nominal charge for additional copies.

Cretors guarantees this machine to be free of defects in parts, materials and workmanship for two years. Please take this time to fill out the factory registration card and return it to Cretors to activate your warranty. If you have any questions concerning the Cretors' warranty, please contact your local distributor or the Customer Service Department at C. Cretors and Company.



C. CRETORS AND COMPANY  
176 MITTEL DRIVE  
WOOD DALE, IL 60191  
PHONE (773) 588-1690, (800) 228-1885, FAX (847) 616-6970  
WEB SITE: <http://www.cretors.com> Email: [postmaster@cretors.com](mailto:postmaster@cretors.com)

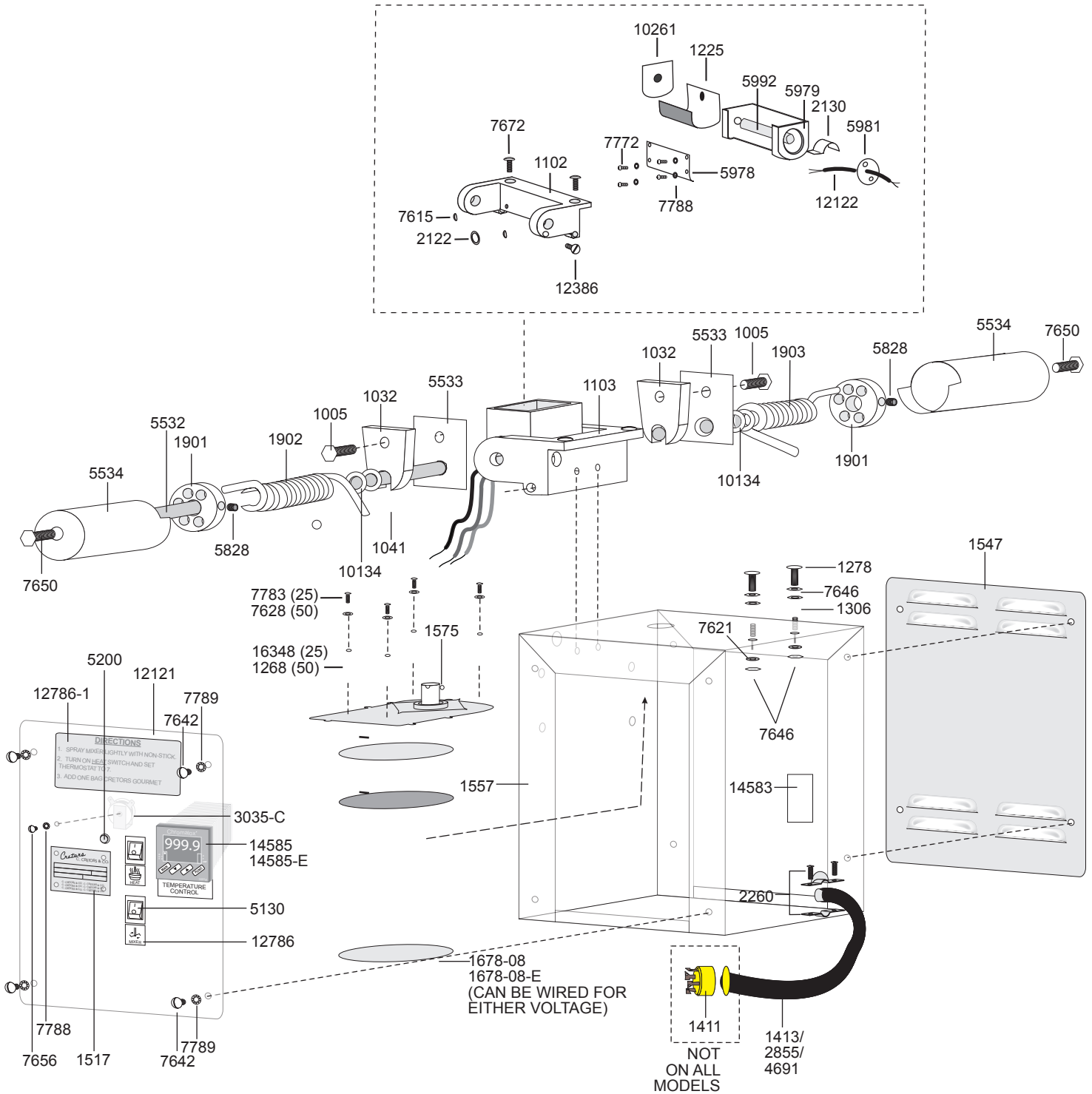



1005	OILITE BEARING	7615	1/4-20 X 3/4 HEX CAP SCREW
1032	CROSS SHAFT LUG	7619	1/4-20 x 1/2 HEX SCREW
1041	PAN DUMP SPRING ROD	7621	1/4" INTERNAL TOOTH LOCKWASHER
1102	KETTLE SUPPORT BRACKET	7622	3/8" FLAT WASHER
1103	TERMINAL HOUSING COVER	7628	1/4-28 X 3/4" HEX HEAD (cmd50)
1225	FISH PAPER	7635	3/8" MED. SPLIT LOCKWASHER
1268	1/4 x 1/4 SPACER (cmd50)	7638	3/8-16 X 1' HEX BOLT
1278	KETTLE LEVEL ADJUSTING SCREW	7642	8-32 x 3/8 S.S. TRUSS HEAD
1306	HEX PAN REST STUD	7646	1/4-28 HEX NUT
1411	PLUG-30 AMP, 125/250V, T,4-WIRE	7650	1/4-20 X 3/8 HEX HEAD
1413	RECEPTACLE-30A 4-WIRE, NEMA	7656	6-32 X 3/8 BINDING HEAD
1547	BACK PANEL - CARMELIZER	7669	3/8-16 HEX NUT
1557	ROLL PIN	7672	10-32 x 1/4 SET SCREW
1569	3/8-16 x 1-1/2 HEX BOLT	7772	6-32 x1/4 BINDING HEAD
1575	1/4 x 1-3/8 ROLL PIN	7780	5/16" FLAT WASHER
1678-08	MOTOR (DOMESTIC&EXPORT)	7783	1/4-28 X 1-1/2" HEX HEAD (cmd25)
1901	SPRING COLLAR	7788	#6 LOCKWASHER
1902	DUMP SPRING - 13 COIL	7789	#8 STAR LOCKWASHER
1903	DUMP SPRING - 10 COIL	10134	1/2" FLAT WASHER
2122	HEYCO BUSHING	10261	FISHPAPER WASHER DIRECT WIRE
2130	PIPE CLAMP	12121	SWITCHPLATE - DIGITAL
2260	1/2" CONNECTOR	12122	WIRE HARNESS
2855	CORD-25 AMP-Export 230V	12386	10-24 x 1" FLAT HEAD SCREW
3035-C	BUZZER - 240 VOLT	12786-1	DECAL - INSTRUCTIONS
4691	CORD - 25AMP, 5X4.0MM-Export 400V ØN	14583	RELAY - 230V. SINGLE POLE
5130	LIGHTED SWITCH	14585	DIGITAL TEMPERATURE 120V.
5200	INDICATOR LIGHT	14585-E	DIGITAL TEMPERATURE CONTROL 230V.
5532	CROSS SHAFT	16348	1/4 x 3/8 x 7/8 STEEL SPACER (cmd25)
5533	CROSS SHAFT LUG		
5534	SPRING COVER		
5828	5/16-24 x 1/2 HALF DOG PT. SET SC		
5978	TERMINAL COVER PLATE		
5979	TERMINAL HOUSING		
5981	BAKELITE WASHER		
5992	INSULATOR TUBE		
7604	CROSS SHAFT		

# DIGITAL CARAMALIZER 50 - KETTLE PARTS

UPSIDE DOWN

BEGINNING SERIAL No. 10080000

DOC: CMD20016

CMD50-2.1-C

8/2010

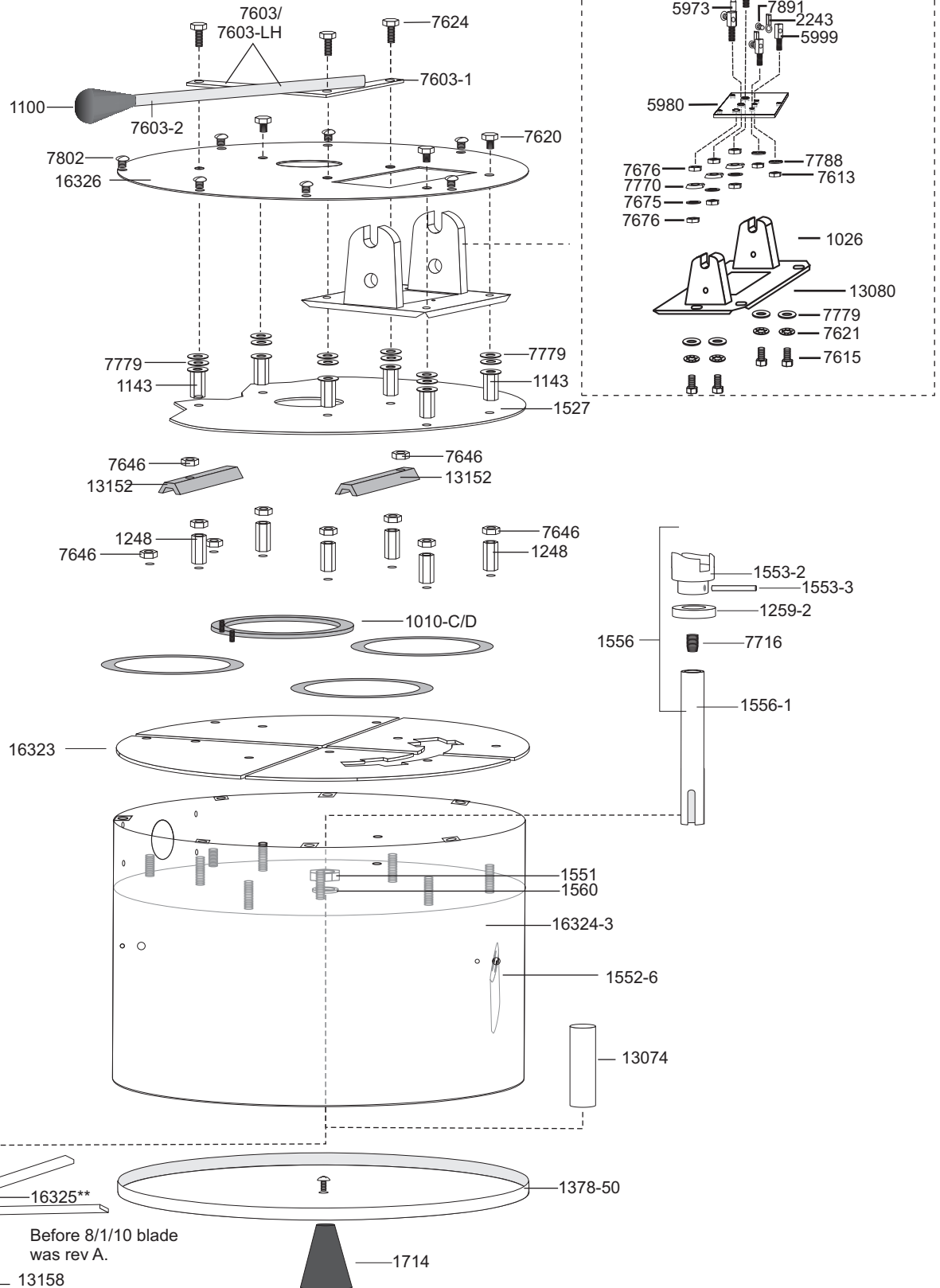

C. CRETORS AND COMPANY

176 MITTEL DRIVE

WOOD DALE, IL 60191

PHONE: (773)588-1690, (800)228-1885, FAX: (847) 616-6970

WEB SITE: <http://www.cretors.com> Email: [postmaster@cretors.com](mailto:postmaster@cretors.com)

**DIGITAL CARAMALIZER 50 - KETTLE PARTS**

DOC: CMD20016

CMD50-2.1-C

UPSIDE DOWN

8/2010

BEGINNING SERIAL No. 10080000

1026	PAN LUG	13074	PAN CENTER STUD- 1/2" SHAFT
1100	KNOB	13080	PAN LEG PLATE CMD25/50
1143	SPACER - HEX W/WASHER	13158	STIRRER CAP-1/2" SHAFT- CMD
1248	SPACER	16323	DIFFUSER PLATE CMD50
1259-2	SHAFT COLLAR W/ SET SCREW	16324-3	CARMELIZER KETTLE-CMD50
1268	1/4" SPACER	16325	SS MIXER BLADE ASSY(REV B)
1769	ELEMENT CLAMP (SMALL)	16326	PAN BOTTOM COVER
13152	ELEMENT CLAMP (LARGE)		
1378-50	MIXER PAN COVER		
1527	BAFFLE PLATE		
1010-C	ELEMENT 750 WATT, 240 VOLT		
1010-D	ELEMENT 750 WATT, 208 VOLT		
1551	CENTER STUD NUT		
1552-5	PAN MIXER		
1552-6	DEFLECTOR-CMD25		
1553-2	CLUTCH DOG ONLY		
1553-3	CLUTCH DOG PIN		
1556	S.S. CLUTCH DOG & SHAFT		
1556-1	S.S. CLUTCH DOG SHAFT ONLY		
1560	LOCK WASHER		
1681	MIXER BLADE DRIVE BOLT-MACH		
1681-1	MIXER BLADE DRIVE BOLT		
1714	KNOB		
5977	WIRE TERMINAL STUD		
5980	MYROY PLATE		
5999	THERMOCOUPLE STUD		
7590-C	KETTLE ASSY 240V COMPLETE-DIG		
7590-D	KETTLE ASSY 208V COMPLETE-DIG		
7603	DUMP HANDLE ASSY		
7603-LH	DUMP HANDLE LEFT HAND		
7676	10-32 MONEL NUT		
7770	#10 CUP WASHER		
7779	1/4" FLAT WASHER		
7789	#8 INTERNAL TOOTHLOCK WASHER		
7802	10-24 x 1/4 BINDING HEAD		
7891	8-32x3/16 SS PAN HEAD SCREW		
12357	THERMOCOUPLE ASSY-CMD25/50		

---

**C. CRETORS AND COMPANY**

176 MITTEL DRIVE

WOOD DALE, IL 60191

PHONE: (773)588-1690, (800)228-1885, FAX: (847) 616-6970

WEB SITE: <http://www.cretors.com> Email: [postmaster@cretors.com](mailto:postmaster@cretors.com)

**EG(PR) 32/48/60 ONE PIECE KETTLE BREAKDOWN**  
**120/208; 120/240; 230V; 400V**

DOC: G2000049

G32/48/60-C/D/E/G-2.1-A  
 05/2010

UPSIDE-DOWN VIEW

BEG. SERIAL NUMBER: 10050604

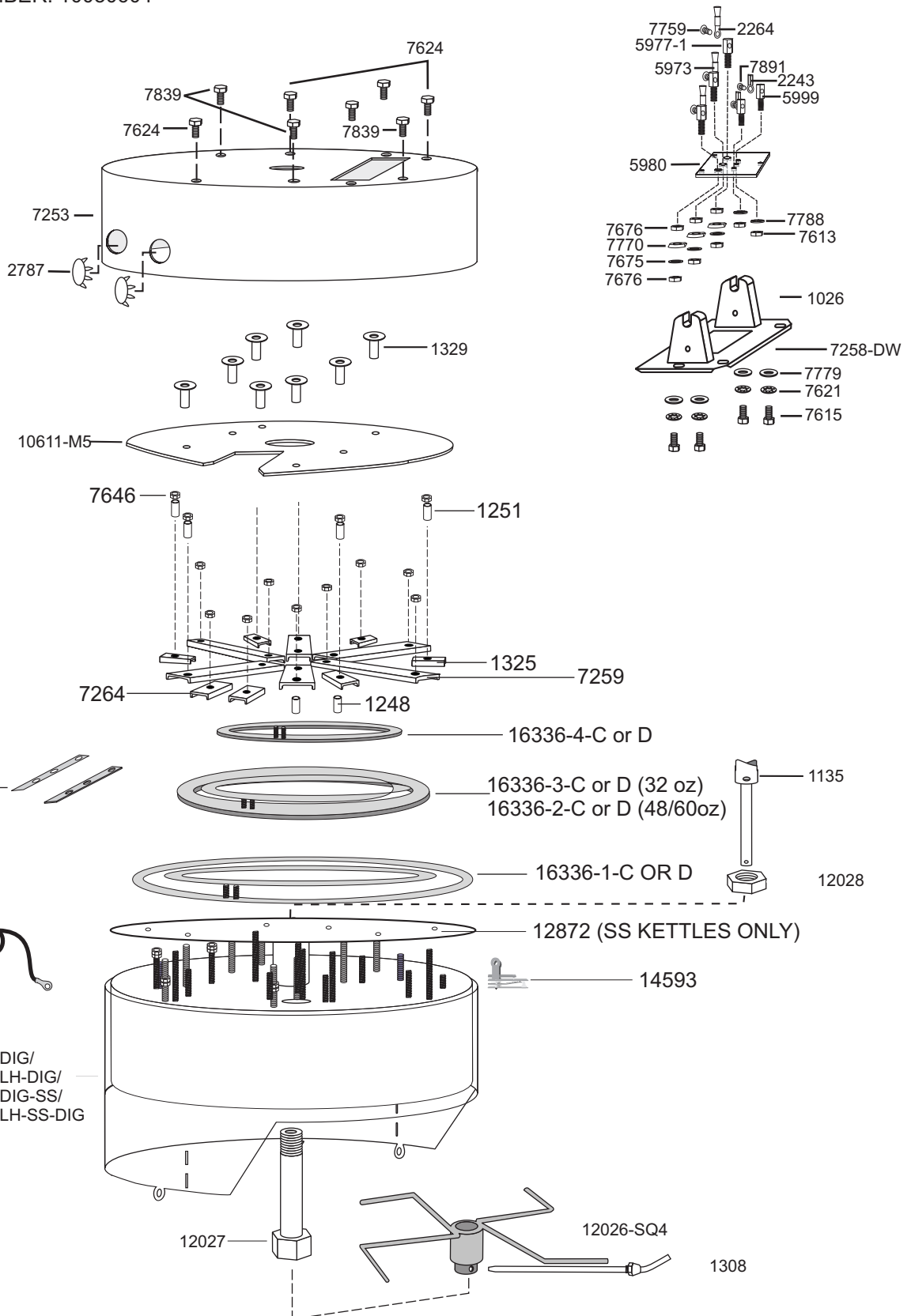

FOR CE MARKED MACHINES, 3918 WAS REPLACED WITH 14593 AND 14942 ON 400v MACHINES BEGINNING 07/08.



14942 (LOCATED IN CABINET)

16394

(400v kettles use 1 16394 and 1 16395 not shown)

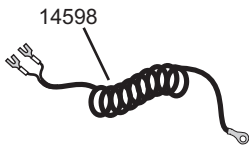
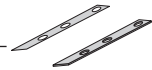

**EG(PR) 32/48/60 ONE PIECE KETTLE BREAKDOWN**  
**120/208; 120/240; 230V; 400V**

DOC: G2000049

G32/48/60-C/D/E/G-2.1-A  
05/2010

UPSIDE-DOWN VIEW

BEG. SERIAL NUMBER: 10050604

1026	PAN LUG	12028	CENTER STUD LOCKNUT
1135	CLUTCH DOG AND SHAFT	12267-DIG	POPPER PAN-ONE PC. DROP-48 OZ -DIG
1251	5/8" SPACER	12267-LH-DIG	POPPER PAN 48 OZ.-LEFT HAND - DIG
1308	ANTI-PAK PIN	12267-SS-DIG	POPPER PAN - SS ONE PC. DROP- 48 OZ DIGITAL
1325	ELEMENT CLAMP 3-1/4"	12267-LH-SS-DIG	POPPER PAN - SS - 48oz - LEFT HAND DIGITAL
1329	RETAINER HEX SPACER	12872	DIFFUSER PLATE
2243	TERMINAL-WIRE	14593	HIGH LIMIT
2264	HIGH TEMP. TERMINAL	14598	THERMOCOUPLE-GIANT
2787	HOLE PLUG 1/2"	14942	HIGH LIMIT-LATCHING RELAY
5973	HEAT SHRINK	16336-1-C	ELEMENT 2000 WATT, 240 VOLT
5977-1	WIRE TERMINAL STUD	16336-1-D	ELEMENT 2000 WATT, 208 VOLT
5980	MYROY PLATE	16336-2-C	ELEMENT 3050 WATT, 240 VOLT (48/60 OZ)
5999	THERMOCOUPLE STUD	16336-2-D	ELEMENT 3050 WATT, 208 VOLT (48/60 OZ)
7253	RETAINER	16336-3-C	ELEMENT 1500 WATT, 240 VOLT(32OZ)
7258-DW	PAN LEG PLATE-G48/60E-DIRCT WIRE	16336-3-D	ELEMENT 1500 WATT, 208 VOLT(32OZ)
7259	ELEMENT CLAMP 5-1/4"	16336-4-C	ELEMENT 750 WATT, 240 VOLT
10611-M5	BAFFLE PLATE	16336-4-D	ELEMENT 750 WATT, 208 VOLT
7264	ELEMENT CLAMP 1-5/8"	16394	NICKEL STRAP-4.5"
7605	KETTLE WIRE SET	16395	KETTLE ELEMENT JUMPER - 400V
7613	6-32 X 5/16 X 7/64 HEX NUT	16400	ELEMENT SPACER
7615	1/4-20 X 3/4 HEX CAP SCREW		
7621	1/4" INTERNAL TOOTH LOCKWASHER		
7624	1/4-28 x 1/2 HEX CAP		
7646	1/4-28 HEX NUT		
7675	# 10 FLAT MONEL WASHER		
7676	10-32 MONEL NUT		
7759	10-32 SCREW		
7779	1/4" SAE FLAT WASHER		
7788	#6 STAR LOCKWASHER		
7797	4-36 x 1/8 SLOTTED BINDER HEAD		
7839	1/4-28 x 5/8 HEX HEAD		
7891	8-32 X 3/16 SS PAN HEAD SCREW		
10313	KETTLE WIRE SET (400V ONLY)		
10611-M5	BAFFLE PLATE		
12026-SQ4	STIRRER BLADE - 4 BLADE SQUARE		
12027	PAN CENTER 1 PC		

C. CRETORS AND COMPANY  
3243 N. CALIFORNIA AVENUE  
CHICAGO, IL 60618

PHONE: (773)588-1690, (800)228-1885, FAX: (773)588-2171

WEB SITE: <http://www.cretors.com> Email: [postmaster@cretors.com](mailto:postmaster@cretors.com)

**PR32,EG32,PR48,EG48,PR60,EG60**  
**ONEPIECEKETTLE&PEDESTAL PARTS**  
**120/208V,120/240V/60Hz**  
**ONE POP & SALT/SUGAR OPTION**  
 BEGINNING SERIAL: 1810000

DOC: G2000050 G1P32/48/60-C/D-2.0-B  
 10/2018

**KETTLE ASSEMBLIES**

- (All have -DIG suffix)  
 7251ZP-C-DIG  
 7251ZP-D  
 7251ZP-C-LH.  
 7251ZP-D-LH  
 7251ZP-C-SS  
 7251ZP-D-SS  
 7251ZP-C-LH-SS.  
 7251ZP-D-LH-SS  
 7594ZP-C  
 7594DWIP-D  
 7594ZP-C-LH.  
 7594ZP-D-LH  
 7594ZP-C-SS  
 7594ZP-D-SS  
 7594ZP-C-LH-SS.  
 7594ZP-D-LH-SS

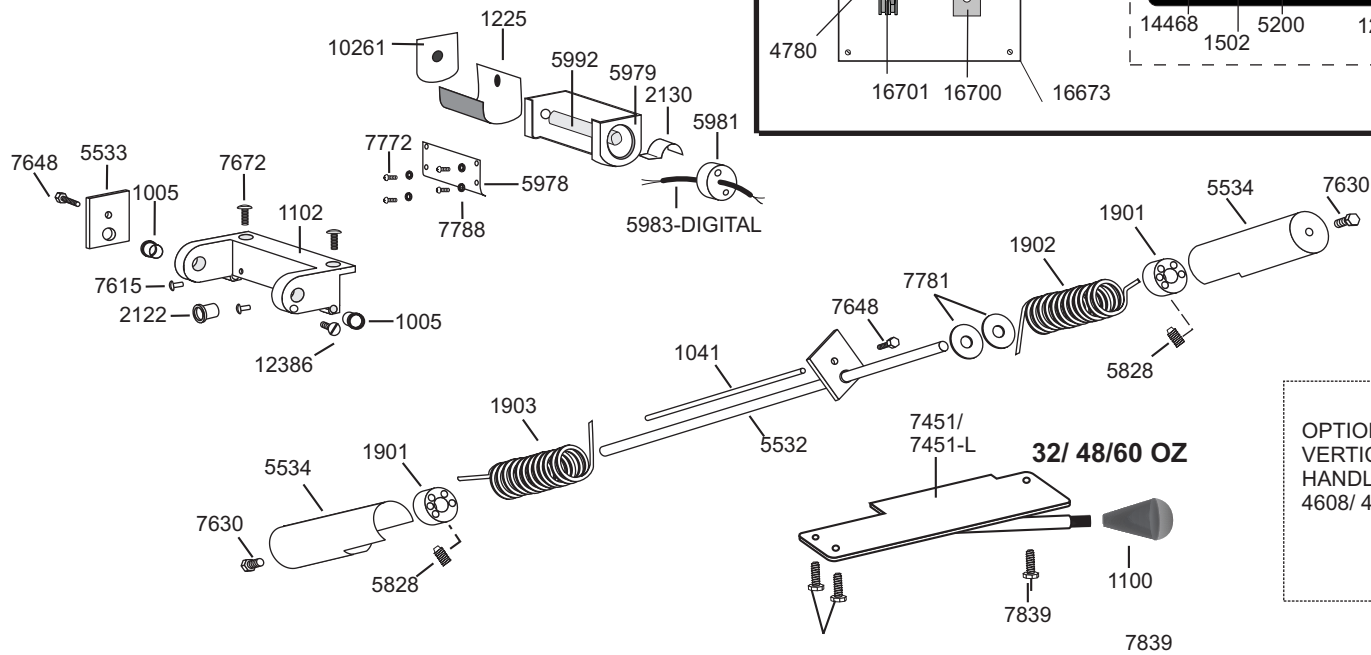
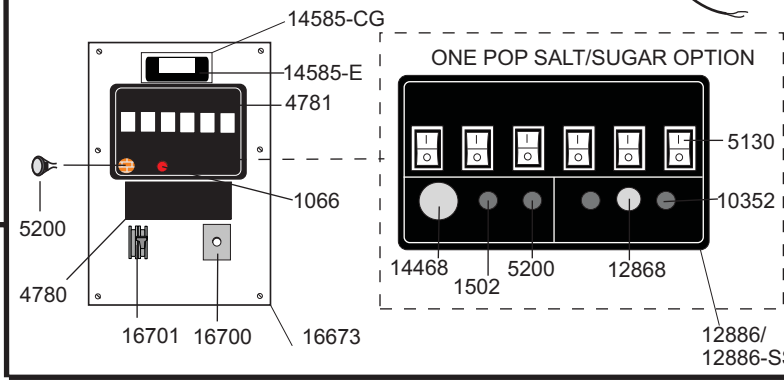
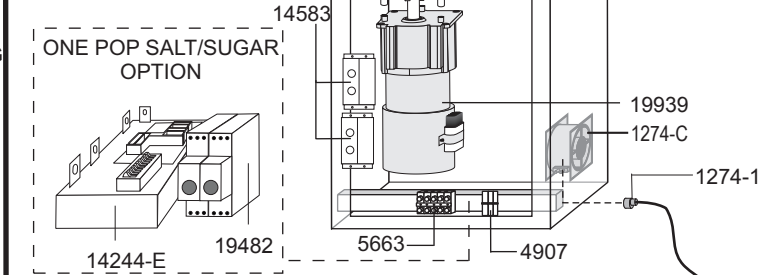
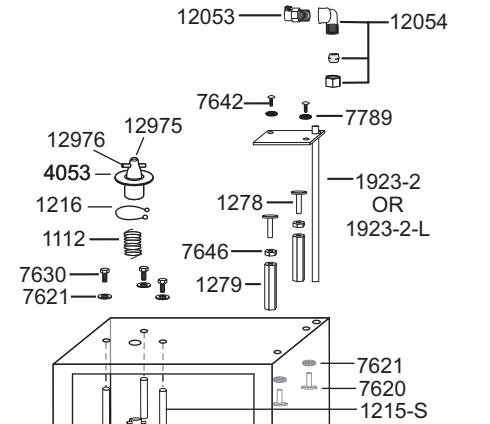
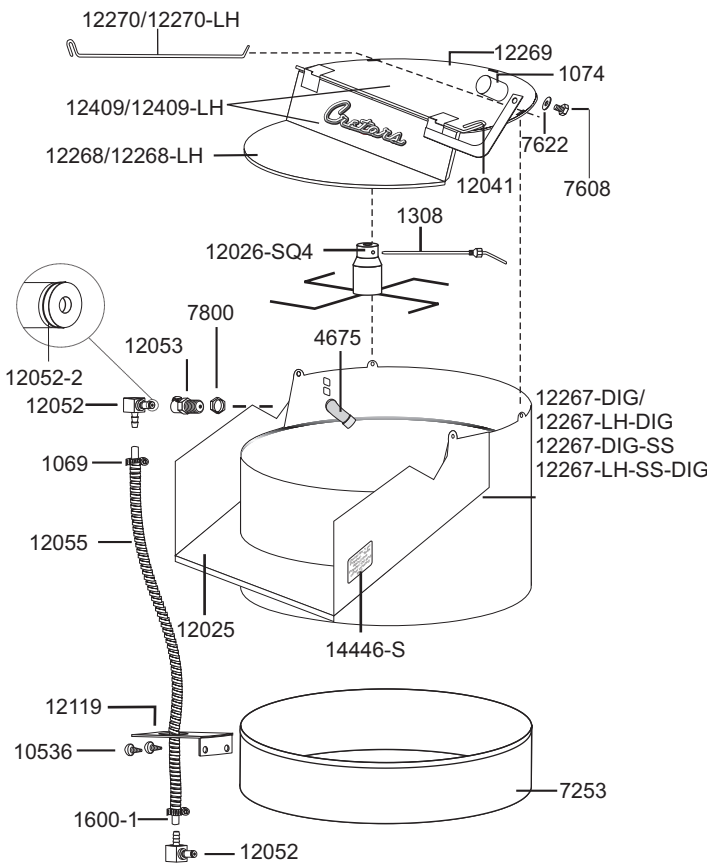

OPTIONAL  
 VERTICAL DUMP  
 HANDLE  
 4608/ 4608-L

**PR32, EG32, PR48, EG48, PR60, EG60**  
**ONE PIECE KETTLE & PEDESTAL PARTS**  
**120/208V, 120/240V/60Hz**  
**ONE POP & SALT/SUGAR OPTION**  
BEGINNING SERIAL: 10050000

DOC: G2000050 G1P32/48/60-C/D-2.0-B  
05/2010

1005	OILITE BEARING	7451-L	DUMP HANDLE - G32/48/60E LEFT HAND
1026	PAN LUG	7608	3/8-24 x 3/8 HEX HEAD
1041	PAN DUMP SPRING ROD	7615	1/4-20 X 3/4 HEX CAP SCREW
1066	SWITCH - PUSH BUTTON	7620	1/4-28 x 3/8 HEX HEAD
1069	CLAMP HOSE	7621	1/4" INTERNAL TOOTH LOCKWASHER
1074	COUNTERWEIGHT	7622	3/8 WASHER
1100	DUMP HANDLE KNOB	7624	1/4-28 x 1/2 HEX CAP
1102	KETTLE SUPPORT BRACKET	7630	1/4-20 x 1/2 HEX BOLT
1112	STIRRER SHAFT SPRING	7642	8-32 x 3/8 SS TRUSS HEAD
1140	PAN CENTER	7646	1/4-28 HEX NUT
1215-S	MOTOR MOUNT STUD SET (3)	7648	5/16-18 x 3/4 CAP SCREW
1216	DRIVE HEAD RETAINING RING	7650	1/4-20 x 3/8 HEX HEAD
1225	FISH PAPER	7659	10-24 x 3/4 FILL HEAD W/SPACER TUBE
19939	MOTOR	7672	1/4-20 x 3/4 OVAL HEAD SCREW
1278	KETTLE LEVEL ADJ. SCREW	7772	6-32 x1/4 BINDING HEAD
1279	KETTLE ADJUSTING SPACER	7779	1/4" SAE FLAT WASHER
1308	ANTI-PAK PIN	7781	1/2 " FLAT WASHER
1319	PAN CENTER WASHER	7788	#6 LOCKWASHER
1502	INDICATOR LIGHT - GREEN	7789	# 8 STAR WASHER
1600-1	TUBING-SILICONE PER FOOT	7800	1/4" NPT HEX THIN NUT
1901	SPRING COLLAR	7839	1/4 -28 x 5/8 HEX HEAD
1902	DUMP SPRING - 13 COIL	7898	10-24 x 1/2 SS WELD SCREW
1903	DUMP SPRING - 10 COIL	7839	1/4-28 x 5/8 HEX HEAD
1923-2	DISCHARGE TUBE BOTTOM- 32 OZ	10261	FISHPAPER WASHER DIRECT WIRE
1923-2-L	DISCHARGE TUBE BOTTOM-LONG	10352	INDICATOR LIGHT W/TABS
2122	BUSHING HEYCO	10536	6-32 x 3/8 SHEET METAL SCREWS
2130	PIPE CLAMP	12025	KETTLE APRON - 1 PC
3913-1	3/8 SS FLEXIBLE CONDUIT	12026-SQ4	STIRRER BLADE ASSY
14446-S	DECAL - CORN	1204	HINGE PIN - 1 PC
4053	MOTOR DRIVE HEAD W/SHIELD	12052	ELBOW - DIRECT OIL
4261	CIRCUIT BREAKER - 120V/15A	12052-2	"O" RING
4675	1/4" SS ELBOW	12053	COUPLING DIRECT OIL
4780	DECAL - INSTRUCTIONS - 20/32/48	12054	1/4" NPT TO 3/8" TUBE RIGHT ANGLE
4781	DECAL - SWITCH	12055	TUBE COVER- 3/8" x 24" SS FLUID CONDUIT
16673	SWITCHPLATE - ROCKER - DIGITAL	12119	OIL TUBE BRACKET
4907	TERMINAL BLOCK 40 AMP	19482	TIMER- 120V/230V DUAL - OFF DELAY
5130	SWITCH - LIGHTED	12268	KETTLE COVER - FRONT
5200	INDICATOR LIGHT	12269	KETTLE COVER - REAR
16701	CIRCUIT BREAKER - 50 AMP	12270	KETTLE COVER PIN
5532	CROSS SHAFT	12409	KETTLE COVER ASSY 1 PC/2 PIN
5533	CROSS SHAFT LUG	12868	TOGGLE SWITCH-3PDT-ON/OFF
5534	SPRING COVER	16673	SWITCHPLATE - ONE POP - DIGITAL
5663	TERMINAL BLOCK	12886	DECAL - ONE POP (SS = SALT SUGAR)
5828	5/16-24 x 1/2 HALF DOG PT. SET SC	12975	1/4-28 X 3/16 SET SCREW
5977	WIRE TERMINAL STUD	12976	DRIVE PIN-MOTOR DRIVE HEAD
5979	TERMINAL HOUSING - DIRECT WIRE	14468	SWITCH-DOUBLE POLE-PUSH BUTTON
5978	TERMINAL COVER PLATE	14583	RELAY-120V.-SINGLE POLE
5980	MYKROY PLATE	14585-E	DIGITAL CONTROLLER - 120V
5981	BAKELITE WASHER	14585-CG	DIGITAL CONTROLLER GUARD
5983-DIGITAL	WIRE ASSY-DW (C,D,E)		
5992	INSULATOR TUBE		
7253	RETAINER - G32/48/60E		
7451	DUMP HANDLE - G32/48/60E		

**C. CRETORS AND COMPANY**  
3243 N. CALIFORNIA AVENUE  
CHICAGO, IL 60618  
PHONE: (773)588-1690, (800)228-1885, FAX: (773)588-2171  
WEB SITE: <http://www.cretors.com> Email: [postmaster@cretors.com](mailto:postmaster@cretors.com)

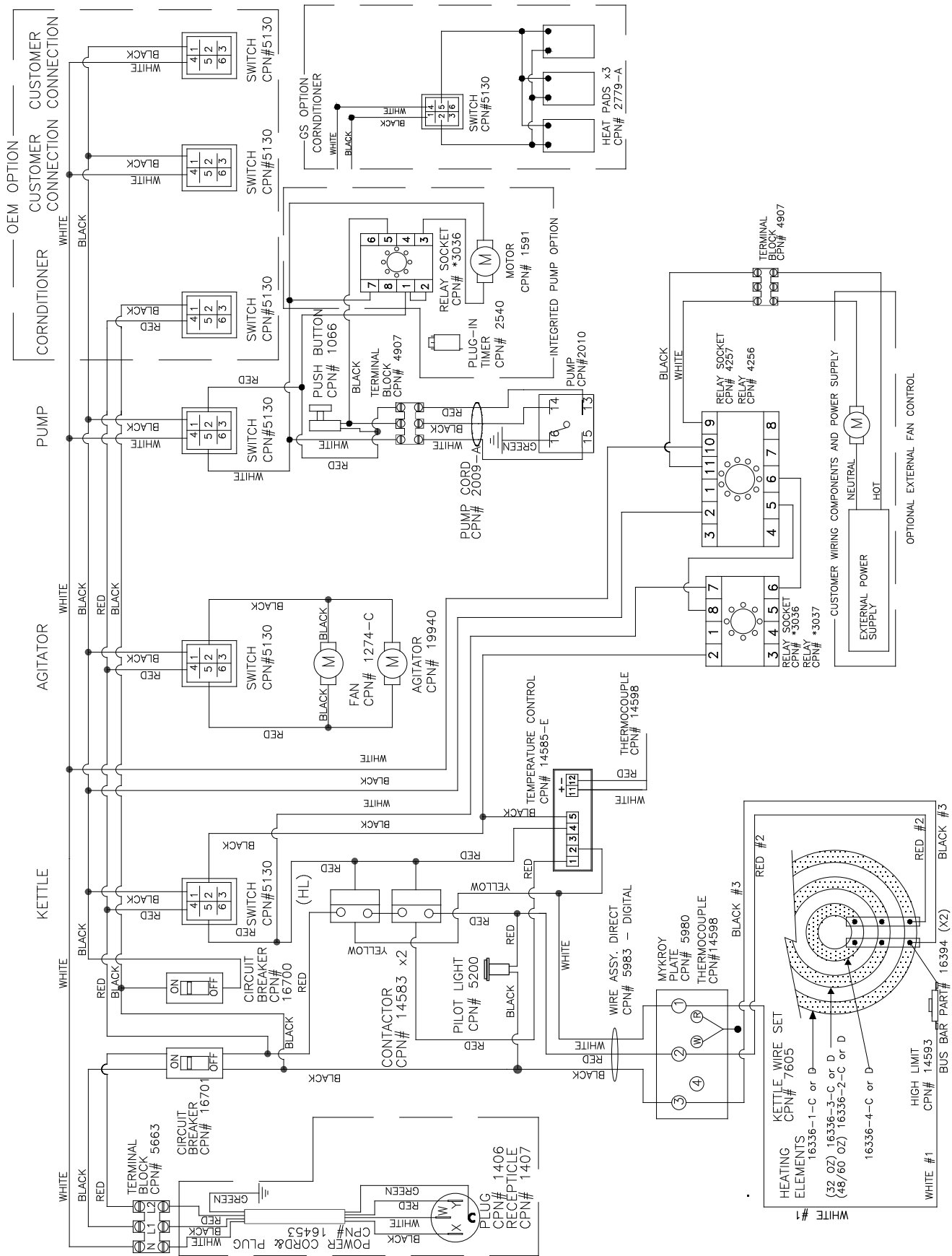



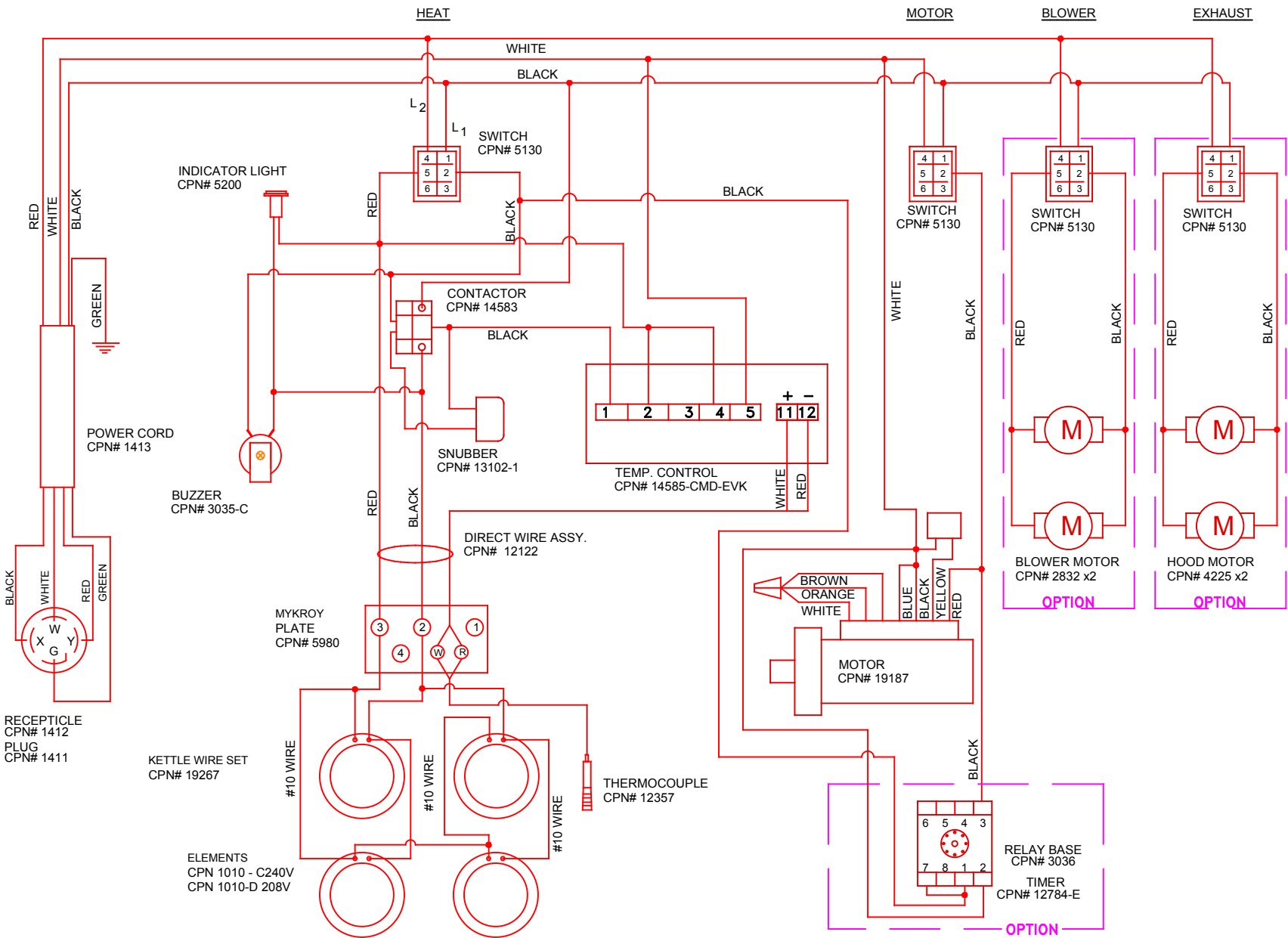

C-CRETORES AND COMPANY  
 170 MITTEL DRIVE  
 WOOD DALE, ILLINOIS 60191  
 PHONE (847) 616-6900, (800) 228-1885, FAX (847) 616-6970  
 WEB SITE: <http://www.cretores.com> Email: [postmaster@cretores.com](mailto:postmaster@cretores.com)