



176 MITTEL DRIVE, WOOD DALE, IL 60191

DIGITAL DIPLOMAT 48 and 60 oz POPCORN MACHINE OPERATION MANUAL

120/208, 120/ 240 Volt,
Single and Three Phase, 60 Hz

230 Volt,
Single Phase and Three Phase, 50 Hz

400 Volt, 3N~
Three Phase, 50 Hz

Included in this manual:

- *One Pop Option
- *Salt/Sugar Option
- *Ventless Hood Option
- *Ansul Option
- *Elevator Option



READ and UNDERSTAND these operating, and safety instructions before operating this popcorn machine

TABLE OF CONTENTS

I. Safety Alert Symbol 3

II. Safety First 3

III. Introduction 3

IV. Purpose of Manual 4

V. Product Identification..... 4

VI. Principles of Popcorn Machine Operation4

VII. Control Switches6

VIII. Operating Instructions6

IX. Sanitation Instructions8

I. SAFETY ALERT SYMBOL

The symbol shown below is used to call your attention to instructions concerning your personal safety and the safety of others. Watch this symbol. It points out important safety precautions. It means **ATTENTION! Become Alert! Your personal safety is involved!** Read the message that follows and be alert to the risk of personal injury or death.



II. SAFETY FIRST



The information in this manual is essential for the safe installation and operation of your Cretors popcorn machine. The manual must be read and understood before installing, or operating this equipment, or equivalent training must be provided.



"The employer shall instruct each employee in the recognition and avoidance of unsafe conditions, as well as, the regulations applicable to his work environment to control or eliminate any hazards or other exposure to illness or injury".
Ref.: 29 CFR 1926.20 (b)(4)(a)(2)



It is understood that safety rules within individual companies vary. If a conflict exists between the safety procedures contained in this manual and the rules of a using company, the more stringent rule should take precedence.



The purpose of equipotential bonding studs, terminals and systems is to join together the metalwork in a product, whether it needs to be grounded or not, so every point is at the same potential/voltage. This bonding is not intended to provide grounding (a separate low resistance ground-fault current path back to the source).

III. INTRODUCTION

This manual is filled with time-saving and money-saving information regarding your Cretors popcorn machine. There is nothing more important than the safety aids and warnings that are throughout this document. The Safety Alert Symbol is used to identify topics of primary safety concern wherever they appear. Furthermore, a separate section has been included which deals exclusively with operation and accident prevention.

If, after reviewing this manual, anything is unclear or technical problems are encountered, contact the distributor from whom you purchased your machine for assistance. If there are any additional questions, feel free to contact our Customer Service Department at the address and/or phone number listed on the last page of this manual. Always have the model and serial number of your machine available to assist in obtaining the correct information.

IV. PURPOSE OF MANUAL

This instruction manual is intended to familiarize owners with the operation, and safety procedures associated with your Cretors popcorn machine.

It is important that this manual be kept available to operating personnel.



A person who has not read and understood all operating and safety instructions is not qualified to operate the machine.

V. PRODUCT IDENTIFICATION

CRETORS POPCORN MACHINE DIPLOMAT MODELS:

DI48 __ - __ - __

DI60 __ - __ - __

VI. PRINCIPLES OF POPCORN MACHINE OPERATION

Theory and Observations of Popcorn Machine Operation

- A. The efficient production of popcorn requires the presence of popcorn kernels, heat, and oil. The purpose of the oil is to distribute the heat throughout kernels evenly and quickly. If the heat is not distributed evenly and quickly, the kernels may burn instead of pop.
- B. In order to pop corn in oil, the kettle, oil and parts near the heating elements are necessarily and unavoidably heated to temperatures high enough to pop popcorn. The temperature controlled using a thermostat located inside the kettle to maintain the kettle at an operating temperature of approximately:

410°F (210°C) for salted corn

375°F (188°C) for sugar corn



Contact with these surfaces will burn and scald you. Do not touch the kettle, oil or parts in direct vicinity of the heating elements.

- C. The kettle is provided with an agitator to assist in the quick and even distribution of heat throughout the kernels.

The oil is heated to high temperatures in a kettle provided with electric heating elements to reach proper popping temperature. An operator is required in the vicinity of the kettle only when handling corn or dumping popped corn from the kettle.



Neither of these operations requires direct contact with the kettle. Direct contact with the hot oil, kettle, or heating elements could result in serious burns or scalds. Keep away from the kettle whenever possible. Use the handle when dumping the kettle, and use the provided cups when necessary to measure corn, oil and salt.

- D. As the popcorn pops, it will push the lid open and discharge into the cabinet. When the corn finishes popping, the corn remaining in the kettle can be removed by holding the kettle handle in your right hand and rotating down in a clockwise direction to dump the kettle.
- E. Your Diplomat model Cretors popcorn popper is equipped for a pump, which, when properly adjusted, automatically delivers the proper amount of oil to the popping kettle.
- F. A conditioner is provided consists of a blower, heating element and thermostat. The conditioner circulates hot air through the corn stored in the popcorn case to keep the product fresh and crisp.
- G. A two-stage filter system traps odor and smoke produced by popping corn. This is replaced when the **Ventless Hood option** is supplied. The ventless hood is integrated into the popping circuit; as such **the popper will not operate if the hood is not functioning!**
- H. One Pop Option only allows the kettle to pop one batch of corn at a time and then shut down. The One Pop Option makes it impossible to leave a kettle heat turned on.
- I. With the One Pop Option, the kettle heat switch is turned on; however, the kettle will not begin to heat until the One Pop button is pressed. When the One Pop button is pressed the green indicator light will go on, the kettle will begin to heat, and the kettle heat indicator light will turn on. The kettle will then heat until the temperature control at the end of the popping cycle. When the temperature control opens at the end of the popping cycle the kettle heat indicator light goes out and the heat turns off. The kettle will not begin to heat again until the kettle has cooled and the One Pop button is pressed.
- J. If the machine is equipped with an oil pump, and the pump switch is turned on, pressing the One Pop button will begin the pumping cycle, as well as, the heat cycle. (When cleaning the kettle and oil is not wanted, turn off the oil switch and the oil pump will not run.)
- L. If the machine is equipped with the Salt/Sugar option, the operator moves the toggle switch to either the salt or sugar position for desired corn type. The oil volume will be set to the appropriate amount. In the salt position, the thermostat will turn off at the sugar temperature but a timer will allow the heat to remain on until the corn has finished popping.
- K. With the Digital Temperature Control, the operator can adjust the set point of the popping cycle on the controller. There is no thermostat in side the kettle. Temperature of kettle will also be displayed. To adjust, see service manual.
- L. If the machine is supplied with the Ventless Hood, refer to the Giles instruction manual for more details on the operation and components. The popcorn popper will not operate if the Giles hood is not fully functional, as part of the UL / EPA testing requires.
- M. If the machine is supplied with the ansul option, in the case of a fire, fire suppression liquid will be discharged into the kettle and cabinet to put out the fire. Power to the circuits will be cut except to the Giles hood. **Ansul must be called to initiate the system at start up.**

VII. CONTROL SWITCHES

*KETTLE HEAT	-Turns the kettle heat On/Off (see exhaust for ventless option)
AGITATOR	-Turns the stirrer blade motor On/Off.
*EXHAUST	-Turns exhaust blower On/Off.
*Ventless Hood option	-The exhaust switch must be turned on for the kettle to heat.
CORNDITIONER	-Turns the cornditioner blower and heat On/Off.
LIGHTS	-Turns interior lights On/Off.
OIL	-Provides power to the oil pump.
DELIVERY	-Initiates the pump cycle.
FUSE/CIRCUIT BREAKER	-Provides protection to all circuits, except the kettle.
ROTARY SWITCH	-Turns power On/Off to all circuits.
ONE POP	-Turns the kettle heat on and initiates the pump cycle.
SALT/SUGAR	-Sets the pump and kettle temperature to proper settings.
DIGITAL CONTROLLER	-Displays and controls kettle temperature.

VIII. OPERATING INSTRUCTIONS



Do not attempt to operate your Cretors popcorn machine until you have read and understood this manual. Failure to do so may result in serious injury or death.



Do not attempt to operate your Cretors popcorn machine unless the installation instructions have been strictly adhered to. Failure to do so may result in serious injury or death.



Operate your popcorn machine only if it is in sanitary condition (See **SANITATION INSTRUCTIONS**). Failure to do so may result in illness to your customers.



Always turn the kettle switch off when not popping corn. Failure to do so will cause oil to stain the kettle, possibly resulting in an unsanitary condition. It may also cause a "flash" fire if oil is added to a kettle left unattended with the heat on, resulting in serious burns or death.



If this machine is equipped with the Ansul option, an ansul representative must be called out to activate the ansul system prior to use. Call 1.800.TO ANSUL for the closest representative.

To operate your Cretors popcorn popping machine:

1. Fill the corn drawer with corn on floor models.
2. Fill the salt box and hang it on the inside edge of the corn drawer.
3. Connect and adjust the pump as explained in the installation instructions. Preheat the popping oil until liquid, if necessary.
4. Fill the corn measure with corn and the salt measure with the salt, and empty these into the kettle. When making sugar corn, add the correct amount of sugar, rather than salt, with the measure for corn.



WARNING! Always add corn to the kettle before pressing the pressing the oil delivery button or adding oil. Failure to do so may result in the oil being heated too rapidly resulting in a fire.



Avoid contact with the kettle. Contact with a hot popping kettle may result in serious burns or scalds.

5. Close the kettle lid by pulling the kettle cover knob down.
6. If equipped, move Salt/Sugar switch to desired mode.
7. Turn on the agitator, the exhaust fan, and then turn on the kettle heat and press the oil delivery button. **For a ventless hood machine, the exhaust must be turned on and be functional for the popper heat to function. When the exhaust switch is turned on, an audible alarm will sound for a few seconds, clicking will be heard, and then the machine will be operational. If the Giles hood will not run, the popping circuit will be disabled until the problem is resolved.**
8. If machine is with the One Pop option, press the One Pop button to begin the popping cycle, and oil delivery.



WARNING! After the first popping the kettle is hot. Avoid contact with the kettle when adding corn or salt. Failure to do so may result in serious burns or scalds.

Measuring cups have been provided to accurately measure the proper amounts of popcorn, salt and oil. The correct amount for each popping is:

SALTED CORN

VOLUMETRIC MEASURE

<u>Kettle Size</u>	<u>Corn</u>	<u>Oil</u>	<u>Salt</u>
48 oz.	48 oz. 1420 ml	16 oz. 473 ml	4 tsp. 20 ml
60 oz.	60 oz.	20 oz.	5 tsp.

1775 ml 591 ml 20 ml

SUGAR CORNVOLUMETRIC MEASURE

<u>Kettle Size</u>	<u>Corn</u>	<u>Oil</u>	<u>Sugar</u>
48 oz. 850 ml	32 oz. 945 ml	11 oz. 325 ml	22 oz. 650 ml
60 oz. 850 ml	48 oz. 1420 ml	15 oz. 445 ml	29 oz. 860 ml

9. As the corn pops, it will push the lid open. When the lid has moved about one and one-half inches, it will open completely, allowing the corn to discharge from the kettle. When the corn finishes popping, when there are four seconds between pops dump the kettle by pulling the large black handle down as far as it will go. Then when the pan is empty, return the handle to its upright position.



Avoid contact with the kettle when dumping popped corn. Failure to do so may result in serious burns or scalds.

10. Repeat steps 4-9 as desired, adding corn to the corn drawer and salt to the salt box as necessary.
11. When the oil container is empty, replace with new full container of oil. See Pump instruction manual.

NOTE: The ideal time for maximum volume (corn expansion) is between 2-3/4 to 3-1/2 minutes from the time the corn is placed into the kettle until the time it is dumped. Check the popping time after several popping cycles. The pilot light should turn off approximately 10-20 seconds before the corn finishes popping. If this is not the case, please refer to the Trouble Shooting Section in your Service Manual.

IX. SANITATION INSTRUCTIONS

Be certain the machine is turned off and power is unplugged before sanitizing this machine unless a specific cleaning procedure requires power to the machine. Failure to do so could result in injury or death.



Do not clean heated surfaces until they have been given sufficient time to cool. Failure to do so may result in serious burns or scalds.

A. Popping Kettle

1. The Cretors kettle is designed to be cleaned in place. There is no need to remove the kettle to clean.



Do not immerse an assembled kettle in water. This will damage the electrical components and may cause short circuits resulting in electrical shock hazard if power is applied.

2. Do not use steel wool or other similar abrasives to clean the nickel plated kettles, as they will ruin the kettle by removing the nickel plating. Stainless steel kettles can be cleaned aggressively.
3. Do not attempt to clean the kettle with power connected unless you are boiling the CKC cleaning compound to clean the inside of the kettle. Follow the instructions in step 6.



Do not attempt to clean a hot kettle. Failure to do so may result in serious burns or scalds.



Do not throw ice into a hot kettle. Doing so can cause damage to the pan and invalidate the warranty.

4. The kettle has a polished nickel finish or is a polished stainless steel finish and is very easy to clean if oil is not allowed to burn. After the final popping, the best practice is to wait until the oil just begins to solidify, then take a cotton towel or absorbent rag and wipe the kettle. Once the oil is allowed to completely solidify, it can become more difficult to remove. We recommend coconut oil for your Cretors popper; it will not stick or burn as easily as other oils.
5. A thorough cleaning every week with CKC cleaning compound is recommended. This will prevent the accumulation of carbon on the bottom and internal sides of the kettle. When boiling the CKC cleaning compound in the kettle, do not fill the kettle with more than $\frac{3}{4}$ " high of water inside the kettle. If the kettle has been overheated or oils that tend to carbonize are used the normal cleaning procedures may not suffice. Increase frequency as needed.

Cretors has developed a cleaning kit for your Diplomat machine. The kit is sold separately under P/N 10831. If you need more information, please feel free to contact your local distributor or call Cretors at 1-800-228-1885.

6. Cretors Outside Kettle Cleaner COC should be used periodically to remove popping oil that may become baked on to the outside of the kettle.
7. The kettle agitator assembly should be removed weekly for thorough cleaning. The stirrer blade is disassembled by removing the spring pin that goes through the top of the stirrer blade. Lift off the stirrer blade.
8. Clean all parts thoroughly, making sure to use CKC. Do not use any harsh abrasives or cleaning materials. Clean the interior of the kettle every week with "CKC" cleaning compound. This will prevent the accumulation of carbon on the bottom and internal sides of the kettle. When using "CKC" cleaning compound in the kettle, do not fill the kettle with more than $\frac{3}{4}$ " high of water inside the kettle. Heat the water to boiling and

turn off the kettle heat, don't boil the kettle dry. If the kettle has been overheated or oils that tend to carbonize are used, the normal cleaning procedures may not suffice. Increase frequency as needed.

9. There are two new Cretors cleaners. Carbon OFF in the blue can is to be used with no heat and the red would require the kettle to be heated. Read the directions on the cans.
10. Reassemble in reverse order, following the directions given.

B. Cabinet

1. Remove and empty the waste clean-out drawer daily or whenever it is full. Under heavy use this may need to be done more often.



Failure to empty the drawer and clean cabinet may result in a fire hazard due to restricted air flow.

2. The cabinet glass and cabinet base can be cleaned with any good grade glass or household cleaner suitable for glass and plastic surfaces. The inside of the cabinet can be cleaned with the same cleaner as the outside, if it is the type that has a cleaning agent to cut the oil remaining from the popping operation, and it is acceptable for food contact surfaces. Do not soak unit with water. Avoid wetting of inside of electrical enclosure.
3. The doors can be cleaned with Cretors' Plastic Polish. This product is specially formulated to clean plastic doors. Do not use cleaners that have ammonia or alcohol. The use of these cleaners will cause the doors to become brittle and crack.
4. Counter model Diplomats require the installation of 4" legs, which are included with this unit. The use of the 4" legs is to conform to food sanitation regulations.
5. The popper case bottom of the 48", 60" and 72" cabinets should be removed at least weekly to thoroughly clean the air chamber beneath. Empty the scraps in the hot air well by removing the clean-out drawer from under the popper case bottom and sliding it under the hot air well. Pull out the clean-out slide and the scrap will fall into the scrap drawer. Dispose of the products found in the popper case bottom, and replace the clean-out slide and the clean-out drawer.
6. Disposable filters should be checked weekly and should be discarded and replaced once filters begin to become saturated but before grease starts to drip.
7. Ventless hood filters need to be cleaned and replaced regularly, see manual for recommended schedule and procedures. Care and caution needs to be taken when cleaning filters as to not damage them, especially the electrostatic filter

Cretors' elevator corn storage option

Elevator

I THEORY AND OBSERVATIONS OF MACHINE OPERATION

The elevating corn storage option is designed to allow operators to easily adjust the level of popped corn in the heated storage bin for easy access. The cabinet is provided with a conditioning system which circulates heated air to keep popcorn warm and crisp. The handle on the outside of the unit is easily turned to raise or lower the poppercase bottom height. This reduces corn breakage and eliminates the need for the operator to reach down into the storage area when the level of popped corn is dropped. The handle may be replaced by a switch if equipped with the motorized elevator option.

II CONTROL SWITCH

TOGGLE SWITCH -Raises and lowers the bin height (motorized model only)

III OPERATING INSTRUCTIONS

1. The height of the bin should be adjusted to the level to hold the amount of corn popped in the cabinet to maximize the efficiency of the conditioning system.
2. The bin level is lowered by pulling and holding out the knob handle while turning the handle clockwise. It is raised by turning counter-clockwise. The bin level can be "locked in position" by releasing the knob handle so that the pin will rest against the underside of the frame. One revolution will raise or lower the bin level by approximately 4 inches.



3. If equipped with the motorized option, the bin level is adjusted by pressing down on the elevator switch to lower and up to raise.

VI SANITATION AND MAINTENANCE INSTRUCTIONS

Emptying the Clean Out Drawer

Remove and empty the clean out drawer daily, or whenever it is full. Under heavy use, this may need to be done more often. The clean out drawer is found under the bin.

Doors may or may not need to be removed to expose the cleanout drawer.

Cleaning Beneath the Popper Case Bottom

Clean the interior of the warming cabinet and beneath the popper case bottom, at least once a week. This is done by lifting out the popper case by the handles off the arms. Replace when finished. At least monthly, the divider should be removed by lifting up and out and the rest of the bin can be cleaned. While the divider is removed, the chain should be lightly lubricated with food grade grease. Replace when finished. The bottom of the divider is located between two pins or a pin and the shaft at the bottom of the warming cabinet.

This appliance shall not be cleaned with a water jet.

This appliance is not intended for use by persons (including children) with reduced physical, sensory or mental capabilities, or lack of experience and knowledge, unless they have been given supervision or instruction concerning use of the appliance by a person responsible for their safety.

Children should be supervised to ensure that they do not play with the appliance.

If the supply cord is damaged, it must be replaced by the manufacturer, its service agent or similarly qualified persons in order to avoid a hazard.

CAUTION: In order to avoid a hazard due to inadvertent resetting of the thermal cutout, this appliance must not be supplied through an external switching device, such as a timer, or connected to a circuit that is regularly switched on and off by the utility.

This machine may or may not be provided with a plug, depending on the voltage. If plug is not supplied, please follow local/country codes to select the proper size and type of plug. Refer to the serial plate attached for the wattage of your piece of equipment.

Warning: Before obtaining access to terminals, all supply circuits must be disconnected.

If you have any questions regarding the operation or cleaning of your Cretors popcorn popper, contact your local distributor. Should you have any difficulties or are unable to reach them, feel free to contact the Customer Service Department at C. Cretors and Company.

Additional copies of this manual can be obtained from C. Cretors and Company at the address listed below. Please provide model and serial number when requesting additional copies of this manual. There will be a nominal charge for additional copies.

Cretors guarantees this machine to be free of defects in parts, materials and workmanship for two years. Please take this time to fill out the factory registration card and return it to the factory to activate your warranty. If you have any questions concerning the Cretors' warranty, please contact your local distributor or the Customer Service Department at C. Cretors and Company.



C. CRETORS AND COMPANY
 176 MITTEL DRIVE
 WOOD DALE, IL 60191
 PHONE (773) 588-1690, (800) 228-1885, FAX (847) 616-6970
 WEB SITE: <http://www.cretors.com> Email: postmaster@cretors.com



176 MITTEL DRIVE, WOOD DALE, IL 60191

**DIGITAL DIPLOMAT 48 and 60 oz.
POPCORN MACHINE
SERVICE MANUAL**

**120/208; 120/ 240 Volt,
Single and Three Phase, 60 Hz**

**230 Volt,
Single Phase and Three Phase, 50 Hz**

**400 Volt, 3N~,
Three Phase, 50 Hz**

**100/200 Volt,
Single Phase, 50 & 60 Hz**

Included in this manual:

- *One Pop Option**
- *Salt/Sugar Option**
- *Ventless Hood Option**



READ and UNDERSTAND these servicing, and safety instructions before servicing this popcorn machine

TABLE OF CONTENTS

I.	Safety Alert Symbol	3
II.	Safety First	3
III.	Introduction	3
IV.	Specifications	5
	A. Electrical Specifications	
	B. Size Specifications	
V.	Purpose of Manual	5
VI.	Installation Instructions	6
	A. Location	
	B. Power Supply	
	C. Connecting Machine to Power Supply	
	D. Pump Installation	
	E. Counter Model Installation	7
	F. Ventless hood Model Installation	7
	G. Ansul Installation	7
VII.	Service Instructions	7
	A. Parts	
	B. Kettle Temperature Control	
	1. Temperature Control Operation	
	2. Digital Temperature Control Adjustment	8
	3. Checking Temperature Control	9
	4. Salt Timer Adjustment	
	5. Salt/Sugar with One Pop Adjustment	10
	C. Kettle Removal	
	D. Kettle Installation.	11
	E. Kettle Alignment	
	F. Kettle Return Spring Adjustment	12
	G. Replacing Damaged Oil Discharge Tube	
	H. Giles hood mantainance	
VIII.	Troubleshooting	13

I. SAFETY ALERT SYMBOL

The symbol shown below is used to call your attention to instructions concerning your personal safety and the safety of others. Watch for this symbol. It points out important safety precautions and procedures. It means **ATTENTION! Become Alert! Your personal safety is at risk!** Read the message that follows and be alert to the risk of personal injury or death.



II. SAFETY FIRST



The information in this manual is essential for safe installation and service of your Cretors popcorn machine. The manual must be read and understood before installing, or maintaining equipment, or equivalent training must be provided.



"The employer must instruct each employee in the recognition and avoidance of unsafe conditions, regulations applicable to his work environment to control and eliminate any hazards or other exposure to illness or injury". Ref.: 29 CFR 1926.20 (b)(4)(a)(2)



It is understood that safety rules within individual companies vary. If a conflict exists between the safety procedures contained in this manual and the rules of a using company, the more stringent rule should take precedence.



The purpose of equipotential bonding studs, terminals and systems is to join together the metalwork in a product, whether it needs to be grounded or not, so every point is at the same potential/voltage. This bonding is not intended to provide grounding (a separate low resistance ground-fault current path back to the source).

III. INTRODUCTION

This manual is filled with time-saving and money-saving information regarding your Cretors popcorn machine. There is nothing, however, more important than the safety aids and warnings that are found throughout this document. The Safety Alert Symbol is used to identify topics of primary safety concern wherever they appear. A separate section has been included which deals exclusively with operation and accident prevention.

If, after reviewing this manual, anything is unclear or technical problems are encountered, contact the distributor from whom you purchased your machine. For assistance and if there are any additional questions, feel free to contact our Customer Service Department at the address and/or phone number listed on the last page of this manual. Always have the model and serial number of your machine available to assist in obtaining the correct information.

IV. SPECIFICATIONS

A. Electrical Specifications:

Diplomat Models are available in any of the following electrical configurations:

120/208 or 120/240 Volts, Single and Three Phase, 60 Hz

230 Volt, Single Phase, 50 Hz

400 Volt, 3N~, Three Phase, 50 Hz

100/200 Volt, Single Phase, 50 or 60 Hz

B. Size Specifications:

MODEL DI48	DIPLOMAT 48 OZ. ELECTRIC COUNTER MODEL
Capacity:	48 oz. All-Steel Kettle, 960 one-ounce servings per hour
Power:	7800 watts
Dimensions:	28"D x 36"W x 50" H - - 71 cm D x 91 cm W x 127 cm H
Net Weight:	189 lbs. (86 kg.)
MODEL DI60	DIPLOMAT 60 OZ. ELECTRIC COUNTER MODEL
Capacity:	60 oz. Stainless-Steel Kettle, 1200 one-ounce servings per hour
Power:	7800 watts
Dimensions:	28"D x 36"W x 50" H - - 71 cm D x 91 cm W x 127 cm H
Net Weight:	189 lbs. (86 kg.)
MODEL DI48	DIPLOMAT 48 OZ. ELECTRIC FLOOR MODEL
Capacity:	48 oz. All-Steel Kettle, 960 one-ounce servings per hour
Power:	7800 watts
Dimensions:	28"D x 36"W x 77-3/4"H - - 71 cm D x 91 cm W x 197 cm H
Net Weight:	390 lbs. (177 kg.)
MODEL DI60	DIPLOMAT 60 OZ. ELECTRIC FLOOR MODEL
Capacity:	60 oz. Stainless-Steel Kettle, 1200 one-ounce servings per hour
Power:	7800 watts
Dimensions:	28"D x 36"W x 77-3/4"H - - 71 cm D x 91 cm W x 197 cm H
Net Weight:	390 lbs. (177 kg.)
MODEL TDI48	TWIN DIPLOMAT 48 OZ. ELECTRIC 6' FLOOR MODEL
Capacity:	2 - 48 oz. Kettle, 960 one-ounce servings per hour
Power:	First popper 8850 watts - second popper 6520 watts
Dimensions:	28"D x 72"W x 77-3/4"H - - 71 cm D x 183 cm W x 197 cm H
Net Weight:	610 lbs. (277 kg.)
MODEL TDI60	TWIN DIPLOMAT 60 OZ. ELECTRIC 6' FLOOR MODEL
Capacity:	2 - 60 oz. Stainless-Steel Kettles, 1200 one-ounce servings per hour
Power:	First popper 8850 watts - second popper 6520 watts
Dimensions:	28"D x 72"W x 77-3/4"H - - 71 cm D x 183 cm W x 197 cm H
Net Weight:	610 lbs. (277 kg.)

V. PURPOSE OF MANUAL

This instruction manual is intended to familiarize owners with the servicing and safety procedures associated with your Cretors popcorn machine.

This manual should be kept available to maintenance personnel.

VI. INSTALLATION INSTRUCTIONS

A. Location

Choose a location for your Cretors popcorn machine that maximizes the ease of operation and maintenance procedures. Be sure to check your local building and fire codes for location restrictions.

B. Power Supply

1. Check the nameplate to determine the required power supply.



Connect your popcorn popper only to the correct power source. Failure to do so may result in personal injury or death and may damage your popper.

2. C. Cretors and Company recommends dedicated circuits for the Diplomat model popcorn machine. The Diplomat model poppers require a dedicated circuit to avoid a voltage drop in the supply wiring. Check your local electrical codes regarding fuse or circuit breaker requirements.



Make certain your popcorn machine is properly grounded. Failure to do so may result in damage to your equipment or present a shock hazard.

C. Connecting your Machine to the Power Supply

1. Make certain that the power supply circuit breakers are in the off position.
2. Push the plug completely into the receptacle. If the cord has a twist lock plug be sure to turn to the lock in position.
3. If the supply cord is damaged, a Cretors approved service agent, or a qualified Cretors employee must replace it in order to avoid a hazard.

D. Pump Installation (and Pump Timer Adjustment for Salt/Sugar Machines)

Refer to the Service Manual included with the pump to be installed in the machine. When the Diplomat is equipped with the salt/sugar option, also see below for additional information.

1. For the Salt/Sugar machine the pump timers are located in the machine not in the pump. One timer is marked "Salt", the other "Sugar".
2. On the 3' Diplomats the timer is located under the wire cover by the rocker switches.
3. On the 4', 5', and 6' machines the timers are located on the top of the machine under the cover. They will be marked Salt and Sugar timer.
4. To adjust the pump time, use the following procedure:

- a. There are two adjustments on the timer. The small adjustment knob sets the maximum time the timer can run. Creators will normally set this adjustment for 10s.

10s = 0-10 seconds

1m = 0-1 minute

10m = 0-10 minutes

- b. The larger adjustment knob sets the actual run time (percentage of time allowed by the small adjustment knob). Example: If the maximum setting is set for 10s and the large knob is set at .9, the timer will run for 9 seconds. Adjust to taste for both timers.

E. Counter Model Installation

The Counter Model Diplomats have 4" legs, which must be attached at the time of installation. The legs are required to comply with Sanitation Standards.

F. Ventless Hood Installation

The Ventless hood Model Diplomats have the Giles ventless hood integrated into the popper. If the hood is not functioning, neither will the popper. Once the machine is plugged in, turn on the "exhaust switch". The hood will sound an alarm and then the alarm should shut off. Once the hood is operational, the rest of the machine functions as normal. Also refer the Giles hood instruction manual for additional information on operation and service.

G. Ansul Installation

An Ansul service technician must be called out to activate the system at start up. There will be no power to the machine until this is done.

VII. SERVICE INSTRUCTIONS



In the case of improper operation, only a qualified person should perform the following diagnostic checks, and, if necessary, corresponding adjustments and repairs. Many of the following procedures may present an electrical shock hazard and can cause serious injury or death.



Perform work only on de-energized circuits. Failure to do so may lead to electrical shock resulting in personal injury or death.

A. Parts

When ordering parts, refer to the parts diagram included with this manual. Always supply the serial number, model number, and voltage of your popcorn machine.

B. Kettle Temperature Control

1. TEMPERATURE CONTROL OPERATION

- a. A digital temperature control is installed as a safety device to prevent the overheating of the kettle if the machine is left unattended momentarily while in operation. The digital Temperature Control senses kettle temperature from a thermocouple mounted on the bottom of the pan. The kettle indicator light indicates the operation of the temperature control. The indicator light is located on the support column or on the ceiling of the cabinet near the support column. The indicator light should stay on for most of the popping cycle. The indicator light will turn off 10-20 seconds before the corn finishes popping and the kettle is dumped. If the indicator light turns off 30 seconds or more before the corn finishes popping, the digital temperature control is set too low and in need of adjustment. If the indicator light remains on after the corn has finished popping the digital temperature control is set too high.



CAUTION: If the corn has dried out, it will not finish popping at normal temperatures and the light will go out early. DO NOT ADJUST KETTLE TEMPERATURE BASED ON POOR QUALITY CORN.



CAUTION: Setting the kettle temperature too high (over 500°F 260°C), can cause a serious fire hazard.

- b. Salt/Sugar Option: The indicator lights on the column switch plate will reflect whether the Salt/Sugar switch is in the sugar mode or salt mode. When the Salt/Sugar switch is in the sugar mode, the digital temperature control alone controls the heat. When the switch is on the salt side the digital temperature control works the same way with one exception, when the digital temperature control opens, it activates a timer which allows the heat to stay on, allowing the corn to finish popping.

2. DIGITAL TEMPERATURE CONTROL ADJUSTMENT



CAUTION: If the machine is equipped with the Salt/Sugar option, the temperature control should only be adjusted when the switch is in the sugar mode. When in salt mode, refer to “Salt Timer Adjustment” section.

- a. Press the “set” button.
- b. Use the up or down arrow buttons to adjust the temperature up or down.
- c. Press the “set” button again. (Note that for safety, this range is limited)
- d. The display will show the temperature go up and down.
- e. You should only raise or lower the temperature 5-10°F at a time.
- f. Set temperature so that the power to heat elements is shut off at the correct temperature.

KETTLE

SALTED CORN

SUGAR CORN

3. CHECKING TEMPERATURE CONTROL

There are two ways of checking that the temperature control is set correctly.

- a. Place a pyrometer over the thermocouple position and turn the kettle heat on. Watch to see that the kettle heat shuts off at the correct temperature. Make adjustments as needed.
- b. The temperature control may be adjusted by observing the operation of the indicator light as described in the "Temperature Control Operation" section. Adjust the temperature control so that the kettle heat shuts off 10 to 20 seconds before the corn finishes popping and the kettle is dumped.



Do not adjust the temperature so high that the pan smokes at the end of the popping cycle. If set too high (over 500°F or 260°C), the kettle can become a serious fire hazard.

- c. Observe two or three cycles of correct operation to be certain everything is working correctly. Your final setting should allow the indicator light to cycle off 10 to 20 seconds prior to dumping the kettle.

4. SALT TIMER ADJUSTMENT

For the Salt/Sugar machine, the salt timer is located on the top of all Diplomats under the top cover marked "Salt Timer." If the machine pops sugar corn fine but there is a problem with salted corn, see below.

- a. If the indicator light turns off 30 seconds or more before the corn finishes popping, the timer is set too low and is in need of adjustment.
- b. There are two adjustments on the timer. The small adjustment knob sets the maximum time the timer can run. Cretors will normally set this adjustment for 1m.

10s = 0-10 seconds

1m = 0-1 minute

10m = **Caution: Never set the timer to 10m**

- c. The larger adjustment knob sets the actual run time (percentage of time allowed by the small adjustment knob). Example: If the maximum setting is set for 1m and the large knob is set at .5, the timer will run for 30 seconds. In this case, the heat will stay on 30 seconds after the thermostat opens.

5. SALT/SUGAR WITH ONE POP ADJUSTMENT

- a. If the Salt/Sugar switch is in the sugar position, use the "Digital Temperature Control Adjustment" section.

- b. If the Salt/Sugar switch is in the salt position, the temperature is adjusted on the One Pop Timer/Relay.
- c. On the Relay there are dipswitches very similar to the timer in our 7700-7900 pumps.
- d. From the factory the dipswitches 7 and 9 will be on. To turn the dipswitches ON the dipswitch needs to be pressed down to the number side opposite of the open side.

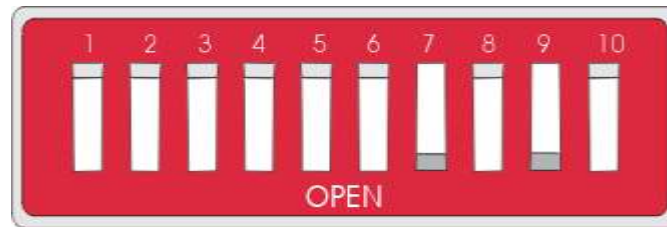

Switch #6 = 5 seconds
 #7 = 10 seconds
 #8 = 20 seconds
 #9 = 40 seconds

Example: If you turn #7 and #9 on, the time delay will be 10 plus 40 or 50 seconds.

C. Kettle High Limit Temperature Control

- a. The kettle high temperature control system is completely redundant system to the digital temperature control. The High limit control controls a second relay which is wired in series with the relay controlled by the digital temperature control.
- b. Cretors "CE" marked machines have been supplied with high limits since 1990 to comply with the European Directives these high limits were not resetting. Once they trip, they must be replaced. Beginning July 2008, the CE marked machines began using the same high limit used in non CE marked machines (cpn14593). These high limits will reset when the temperature falls below their set point. In order to comply with the CE directive a latching relay (cpn 14942) has been added to the control circuit. If the high limit opens the relay will keep the kettle power off until it is reset. The relay is reset by turning off the power to the machine. This is done by turning the rotary switch off and back on or powering the unit off at the main breaker.



CAUTION: If high limit continually trips, check for a problem with the kettle temperature control, temperature setting of the temperature control or the timer setting of the sweet/salt timer

- c. Beginning in May of 2006 UL requires that all cooking machines have auto-resetting thermostats. Cretors and Company has started implementing auto-resetting high limits into our repair kettle assemblies as well. Again, the end customer/user will not see any difference in the operation of their machine but there is now an added level of safety so that the kettle temperature will not be able to exceed a safe level, even if the normal operating thermostat or temperature controller is adjusted to an unsafe level. This high limit is preset and is NOT to be adjusted for any reason.

Tampering with the high limit will void all warranties. New wiring diagrams will be sent out with the new kettle assemblies for reference.

D. Kettle Removal

To remove the kettle assembly, perform the following operations:

1. Unplug the popcorn machine from the power supply. Make sure the kettle is not hot.
2. Remove the retainer patch from around the dump shaft.
3. Remove the hex screws on the bottom of the retainer and remove the retainer.
4. Disconnect the lead wires from the mica terminal plate. If digital, also remove thermocouple wires.
5. Loosen the two square-head setscrews that hold the kettle support plate(s) to the support shaft.
6. Slide the kettle off of the support shaft.



Use proper lifting techniques when removing the kettle assembly to avoid injury to back.

7. If wires must be replaced, be sure to use nickel wire supplied by Cretors. Conventional copper or "stove" wire will have a limited life.
8. When removing nuts and spacers from the threaded studs on the bottom of the pan, do not wipe off the silver lubricant. Without the lubricant (NEVER SEEZ) the nuts may freeze on the studs and cause the studs to break when the nuts are turned, in an attempt to remove them.

E. Kettle Installation

1. When re-assembling the kettle, be sure all nuts and bolts are tight. Check to make sure that all electrical connections are secure. A loose connection can heat up and burn off the wires.
2. Check the kettle support bar to be sure that it is level.
3. Locate the kettle so that the drive shaft lines up with the blade center, and tighten the bolts on the kettle support plate/(s) that hold the kettle in place.
4. Turn on the agitator and dump the kettle. If the drive shaft does not engage and disengages freely, readjust the kettle. Under normal circumstances if the kettle was aligned before it was removed, the only adjustment needed is to slide it in or out along the support shaft until the drive shaft is aligned with the blade center. In severe cases it may be necessary to make further adjustments, see "Kettle Alignment" section for instructions.

5. When the drive shaft engages and disengages freely, securely tighten the other bolts that are holding the pan.
6. Replace the retainer and the retainer patch.

F. Kettle Alignment

1. Begin by checking to see if the kettle support bar is level. With the kettle removed, apply slight downward pressure on the dump handle to simulate the weight of the pan. Measure the distance from the top of the bar to the top of the cabinet at both the tip and at the base near the support column. The measurements should be equal to within 1/8 inch (3 mm). This dimension should be approximately 11 and 7/8 inches (30.16 cm).
2. If the bar is not level, remove the cover from the support column. Locate the kettle level nut and loosen the setscrews that hold it to the shaft. With the setscrew loose, rotate the nut to move the support bar up or down. When level, retighten the setscrews.
3. When the bar is level and properly aligned, the agitator drive shaft should be directly above it. If the bar is not under the drive shaft it can be moved to either side by rotating the entire support column. The support column is rotated by loosening the four bolts that attach it to the top of the cabinet. Re-tighten and re-check the alignment.

G. Kettle Return Spring Adjustment

The kettle counter balance return spring holds the kettle in a level position when popping corn. It allows the kettle to be emptied when the handle is pulled down. The fixed end of the spring is held by a hooked plate with four adjustment points. The tension of this spring is adjusted by sliding a small tube over the fixed end of the spring and moving it to a different adjustment point.

H. Replacing Damaged Oil Discharge Tube

If the oil discharge tube, which terminates within the kettle, becomes damaged, the tube can be replaced easily. By using a 9/16 wrench to loosen and remove the bottom piece of the coupling. Pull the damaged tube out and replace it with P/N 1089-1 tube.

Make sure the mitered end of the tube is facing the opposite direction of the stirrer blade rotation. This is so that the unpopped kernels are not forced up into the tube. Tighten up the coupling.

I. Giles Hood

The filters contained within the Giles hood need to be cleaned and replaced on a regular basis. All filters must be in good operating condition and in place for the hood and popcorn machine to function properly. Filters must be cleaned as recommended in the Giles manual to prevent damage to the filters. Please refer to the Giles manual supplied for additional service requirements for the Giles ventless hood.

VIII. TROUBLESHOOTING

PROBLEM	POSSIBLE CAUSE	ACTION
Popping is slow.	Incorrect amount of corn and oil used.	Refer to the chart located in the Operations Manual.
	Kettle indicator light goes out more than 30 seconds before the corn finishes popping.	Temperature is set too low (refer to "Digital Temperature Control Adjustment" section). Temperature is set too high (refer to the "Salt Timer Adjustment" and "Salt/Sugar One Pop Adjustment" sections).
	Voltage may be low.	Check the voltage at the circuit breaker with the kettle heat on. Extension cords or inadequate wiring will provide full voltage, if no load is applied. Once the kettle heat and auxiliaries are turned on, the voltage may drop 5 to 10 volts.
Indicator light stays on.	One of the elements in a multi-element pan may have failed.	Use an ammeter to diagnose.
		<p>Check the amperage draw of the heating elements, by using a clamp-on ammeter.</p> <ol style="list-style-type: none"> 1. Remove the top of the machine by removing the screws that hold the top panel and lift the top off. 2. Turn on the kettle heat. 3. If machine has one-pop option shut off the oil switch and press the one-pop button. 4. Place the ammeter around the lead to the popper kettle as listed. The following current draws are normal. 120/208-240V and 100/200V machines-black or red 230V machines-blue or brown 400V machines-black or brown



Do not adjust the temperature so high that the pan smokes at the end of the popping cycle. If set too high (over 500°F or 260°C), the kettle can become a serious fire hazard.

<u>Kettle</u> 48/60 oz.	<u>Wire Color</u> red black	<u>120/208 Volts</u> 27.8 amps 27.8 amps
-----------------------------------	--	---

<u>Kettle</u> 48/60 oz.	<u>Wire Color</u> Red black	<u>120/240 Volts</u> 24.1 amps 24.1 amps
-----------------------------------	--	---

<u>Kettle</u> 48/60 oz.	<u>Wire Color</u> brown Blue	<u>230 Volts</u> 24.1 amps 24.1 amps
-----------------------------------	---	---

<u>Kettle</u> 48/60 oz.	<u>Wire Color</u> Brown black	<u>400 Volts</u> 13.2 amps 11.9 amps
-----------------------------------	--	---

PROBLEM	POSSIBLE CAUSE	ACTION
<p>A low reading may indicate a problem in the kettle. One or more of the heat elements may not be functioning properly. If the element is not functioning, the possible causes are:</p> <ol style="list-style-type: none"> 1. The element has burned out. 2. A lead wire has burned off one of the element terminals due to a loose connection. 		<p>In either case the kettle must be removed and the problem identified.</p> <ol style="list-style-type: none"> 1. Remove kettle. (See section Kettle Removal for instructions.) 2. Check for short circuits inside the kettle. 3. If wires must be replaced, be sure to use nickel wire supplied by Cretors. Conventional copper or "stove" wire will have limited life. 4. Make a visual check for broken, loose, burned or heat damaged wires. If there are no obvious broken or loose wires shorting out on the kettle, the elements must be checked. 5. Perform a continuity test on the elements. It is possible that one of the elements has burned through the insulation and the casing is shorting out directly to the kettle bottom.

Continuity Test and Ohms Test

When checking Ohms, make sure that the meter probes are making good contact on the terminals. Remove the nickel buss bars that connect the electrical terminals on the heat elements.

Using a multimeter, check each element between the following points:

Terminal to terminal	Ohm readings should match chart listed below. If Ohm readings are not close, replace.
First terminal to element case	Continuity to case from terminal indicates a grounded element; replace. No continuity - functioning properly.
Second terminal to element case	Continuity to case from terminal indicates a grounded element; replace. No continuity - functioning properly.

48/60 oz. - 240V elements	1010-C	750 Watt - 76.8 Ω
	1808-C	1250 Watt - 46.1 Ω
	1447-C	1800 Watt - 32.0 Ω
	1043-C	2000 Watt - <u>28.8 Ω</u>
		9.9 Ω (total)

48/60 oz. - 208V elements	1010-D	750 Watt - 57.7 Ω
	1808-D	1250 Watt - 34.7 Ω
	1447-D	1800 Watt - 24.0 Ω
	1043-D	2000 Watt - <u>21.6 Ω</u>
		7.5 Ω

Replace failed heat elements with identical units available from your local dealer or from Cretors. Reassemble and reinstall kettle assembly onto the machine.



Do not attempt electrical repairs on the power supply circuit unless you are qualified to do so. The electrical shock associated with line voltages can cause serious injury or death.



The following procedures are performed with the power on. As with any electrical repairs, there is a shock hazard present.

PROBLEM	POSSIBLE CAUSE	ACTION
Kettle will not heat	<p>The motor, light or any of the other components do not work.</p> <p>Other components work but kettle switch light is not on – see item 5.</p>	<p>Check power supply:</p> <ol style="list-style-type: none"> 1. Is it plugged in? 2. Is the receptacle live? 3. Is the machine plugged into the proper voltage? (Measure with voltmeter and compare to specification on nameplate of machine.) 4. Is ansul system activated (if supplied) 5. Make sure the exhaust switch is ON for ventless hood machines
	If kettle switch is on (lit) but no heat – the problem is in the machine.	<p>Check the relay. The Diplomat digital temperature control uses a relay/contacter to control the power to the popper pan heat elements. To check the relay/contacter, perform the following operations:</p> <ol style="list-style-type: none"> 1. To gain access to the relay/contacter, remove the top of the machine by removing the screws on the top. 2. Using a voltmeter, check the power to the relay/contacter coil, that are the small terminals in the center. 3. With the popper switch on, at room temperature, the digital temperature control should be calling for heat and providing power to the relay. If the coil reading is not 120 volts, (230 volts on 230V and 400V, 50Hz machines) the problem is in the digital temperature control. 4. If the coil reading is 120 volts, (230 volts on 230V and 400V machines) check the voltage between the output terminal with wire #1 and the output terminal with wire #3 from the kettle support. If this does not have a reading of 208 or 240 volts, the relay is not functioning and needs to be replaced.
	If machine has the one-pop option.	<p>Use the same procedure as above. Then check the one-pop circuit.</p> <ol style="list-style-type: none"> 1. With the power OFF. Check the one-pop switch for continuity by pressing and holding it down. Remove wires (mark wires for proper re-installation) from switch and press and hold. Using a multimeter, check for continuity from top to bottom of switch. If no continuity, replace switch. 2. Check the input (COM) and output (NO), on timer/relay.

PROBLEM	POSSIBLE CAUSE	ACTION
Digital Temperature Control display shows EO	Thermocouple has bad connections.	Check all connections.
	Thermocouple is bad. Should read 3-5 ohms if good.	Replace thermocouple.
Corn Burns	Agitator is not working.	Check to be certain the stirrer blade is on the bottom of the pan and is stirring the corn.
	Does the agitator driveshaft engage the blade center and turn it?	See section Kettle Alignment for instructions.
	Does the kettle sag when corn is added to the kettle causing the agitator to disengage?	See section Return Spring Adjustment for instructions.
	Check motor connections.	Loose wire.
	The motor is bad.	Replace.
	The correct amounts of corn and oil were not used.	See Operations Manual for correct amounts.
	Temperature is set too high.	Adjust temperature. (See Thermostat Adjustment Section.)
Problem in the Cornditioner.		
<p>The Diplomat series of machines has four cabinet sizes: 36", 48", 60" and 72". The heat system in the 36" cabinet consists of a blower, heating element, and two thermostats mounted in the base of the cabinet. The upper thermostat is a manual reset high limit with a red button reset. The lower thermostat controls the temperature of the air supplied by the cornditioner. The cornditioner circulates hot air through the popper case to keep popped corn fresh and crisp.</p>		
With the power connected, turn the cornditioner on.		
The switch light is on and no air is being delivered.	Check the high limit thermostat.	If tripped (red button out) reset by pressing red button.
	Check connections to blower.	Replace blower.
The switch light is on and cool air is being supplied.	Check element.	Replace element.
	Check thermostat.	Replace thermostat.
The high limit trip goes off repeatedly.	Cornditioner screen blocked.	Clear passageway.
	Blower is not operating properly.	Replace blower.
	Bottom thermostat is stuck in on position.	Replace thermostat.
<p>The Cornditioner heat system, in the 48", 60" and 72" cabinets, is the same and consists of a blower, heating element, and two thermostats mounted in a removable box. The upper thermostat is a manual reset high limit with a red button reset. The lower thermostat controls the temperature of the air supplied by the cornditioner. The cornditioner circulates hot air through the popper case to keep popped corn fresh and crisp. An indicator light on the cornditioner switch indicates when there is power to the circuit.</p>		
With the power connected, turn the cornditioner on.		

PROBLEM	POSSIBLE CAUSE	ACTION
The switch light is on and no air is being delivered.	Check connections to the blower.	Replace blower.
The switch light is on and cooler air is being supplied.	Check element.	Replace element.
	Check thermostat. The maximum air output temperature is approximately 140° F or (60° C). The thermostat is installed as a safety device and is not adjustable.	Replace thermostat.
The indicator switch is on and air from blower is too hot.	Cornditioner screen is blocked.	Clear passageway.
	Blower is not operating properly.	Replace blower.
	Thermostat is stuck in on position.	Replace thermostat.
Exhaust odors.		Wash grease filter.
		Replace charcoal media in the charcoal filter box.
Pump will not heat.	Pump switch is on.	Check pump switch. Remove wires from switch (mark wires for proper re-installation). Using a multimeter, check for continuity from top to bottom of switch. If no continuity, replace switch.
Pump will not pump oil.	Check One Pop Switch.	Remove wires (mark wires for proper re-installation) from switch and press and hold. Using a multimeter, check for continuity from top to bottom of switch. If no continuity, replace switch.
	Check timer.	Check the input and output power to the pump timer, which is located in the pump or for Salt/Sugar Option: Diplomat timer is located under the wire cover. Diplomat 4', 5' or 6' machines, timers are on top.
	Check motor.	Check power at motor connection. If there is power at motor connection, but motor does not work, replace motor.

This appliance is not intended for use by persons (including children) with reduced physical, sensory or mental capabilities, or lack of experience and knowledge, unless they have been given supervision or instruction concerning use of the appliance by a person responsible for their safety.

Children should be supervised to ensure that they do not play with the appliance.

If the supply cord is damaged, it must be replaced by the manufacturer, its service agent or similarly qualified persons in order to avoid a hazard.

CAUTION: In order to avoid a hazard due to inadvertent resetting of the thermal cutout, this appliance must not be supplied through an external switching device, such as a timer, or connected to a circuit that is regularly switched on and off by the utility.

This manual is filled with time-saving and money-saving information regarding your Cretors popcorn popper. There is nothing, however, more important than the safety aids and warnings found throughout this document.

If you have any questions, contact your local distributor and if there are any additional questions, feel free to contact the Customer Service Department at C. Cretors and Company.

Additional copies of this manual can be obtained from C. Cretors and Company at the address listed below. Please provide model and serial number when requesting additional copies of this manual. There will be a nominal charge for additional copies.

Cretors guarantees this machine to be free of defects in parts, materials and workmanship for two years. Please take this time to fill out the factory registration card and return it to Cretors to activate your warranty. If you have any questions concerning the Cretors' warranty, please contact your local distributor or the Customer Service Department at C. Cretors and Company.



C. CRETORS AND COMPANY
176 MITTEL DRIVE
WOOD DALE, IL 60191
PHONE (773) 588-1690, (800) 228-1885, FAX (847) 616-6970
WEB SITE: <http://www.cretors.com> Email: postmaster@cretors.com

**DIPLOMAT 48/60 OZ.
MOTOR AND KETTLE ASSEMBLY**

DOC: Di300048e

DI48/60-C/D/E/G-2.3-E

07/11

BEGINNING SERIAL: 11070000

ANY OF THESE "PIN" OPTIONS
WILL WORK WITH ALL DIPLOMATS,
BUT 14947 IS RECOMMENDED
FOR ALL REPLACEMENT ORDERS.

OLD STYLES

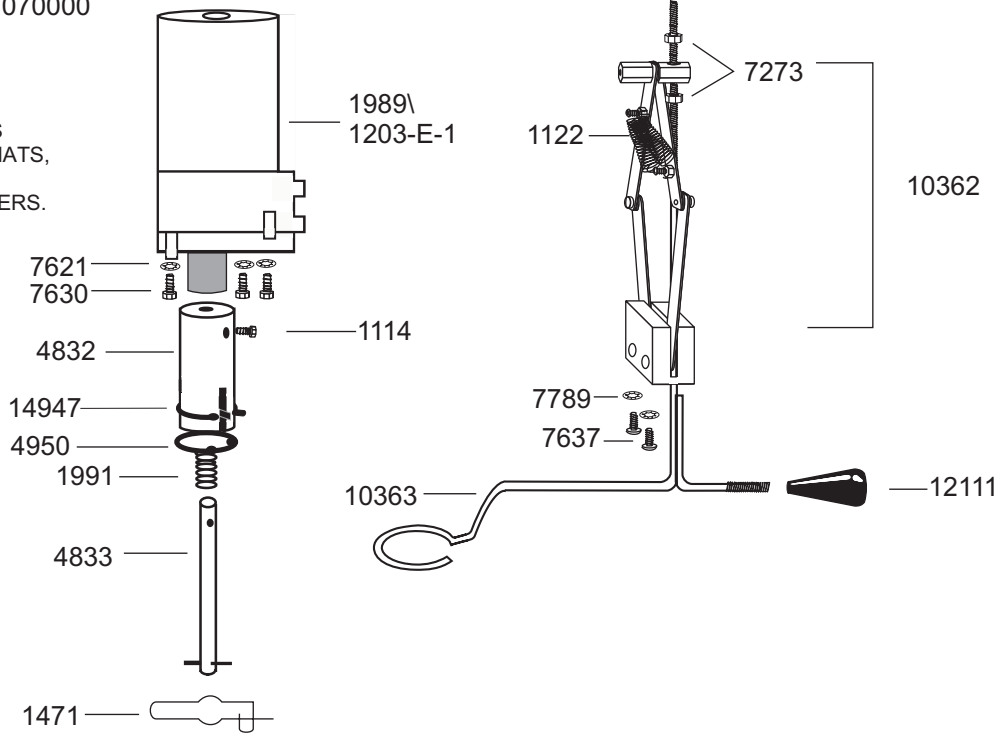
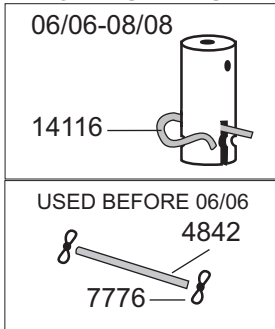

BEFORE 2/17/11
USED 14602
BETWEEN 2/17/11
AND 6/13/11
USED 16550
AFTER 6/13/11
16613

BEFORE 6/13/11
USED 14601
AFTER 6/13/11
16614

NOTE:
If replacing 10365 cover with 14601,
14601-KIT needs to be ordered to
install correctly.

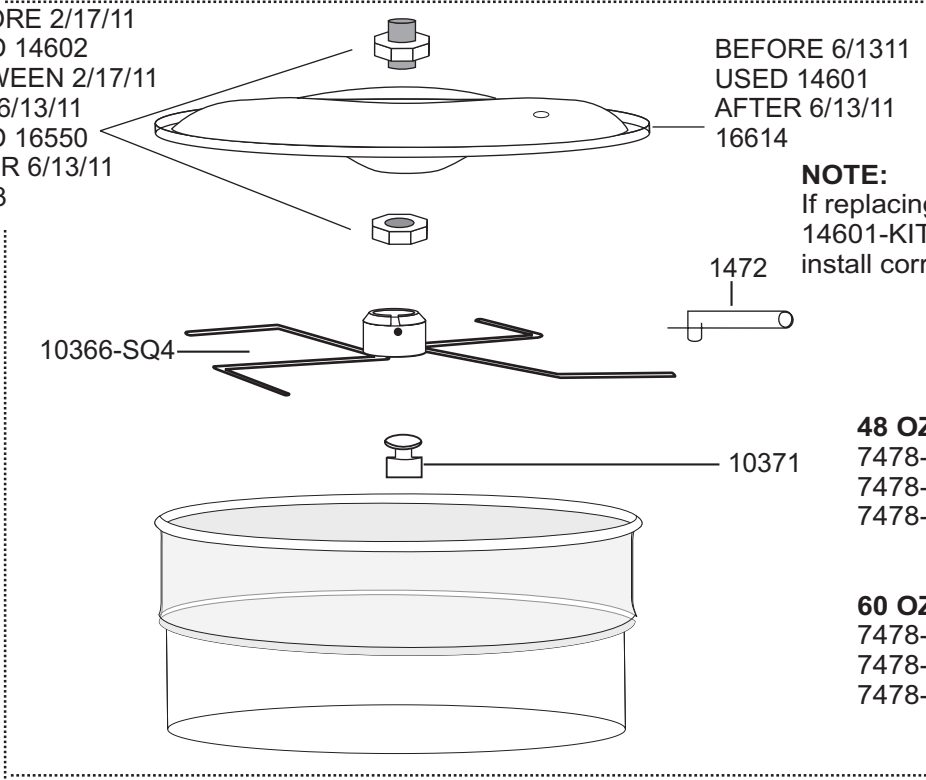

48 OZ. KETTLE

7478-48-C	120/240V (230V)
7478-48-D	120/208V
7478-48-G	400V

60 OZ. KETTLE

7478-60-C	120/240V (230V)
7478-60-D	120/208V
7478-60-G	400V

**DIPLOMAT 48/60 OZ.
MOTOR AND KETTLE ASSEMBLY**

DOC: Di300048e

DI48/60-C/D/E/G-2.3-E
07/11

BEGINNING SERIAL: 11070000

1114 HEX CONNECTOR SET SCREW
1122 TRIP ARM SPRING
1147 NSF-COVER CENTER AND NUT
1203-E-1 MOTOR-PINNED EXPORT
1471 COVER RETAINING SPRING
1472 STIRRER BLADE RETAINING SPRING
1989 MOTOR DOMESTIC
1991 SPRING
4832 DRIVE SHAFT CONNECTOR
4833 DRIVE SHAFT AND PIN SPRING DUMP
4842 SHAFT/CONNECTOR BOLT W/ WING NUT-
REPLACED BY 14116
4950 RETAINING RING
7273 ¼ x 20 HEX STOP NUT
7621 1/4" INTERNAL TOOTH LOCKWASHER
7630 1/4 x 20 x 1/2" HEX BOLT
7637 8-32 x 1/2 SS TRUSS HEAD
7776 8-32 STEEL WING NUT
7789 #8 STAR LOCKWASHER
7865 10-32 ELASTIC STOP NUT
10362 AUTOMATIC COVER LIFT
10363 COVER LIFT ROD
10365 KETTLE COVER (OLD STYLE)
10366-SQ4 STIRRER BLADE-SQUARE
10371 PAN CENTER
12111 KNOB
14116 KETTLE SHAFT PIN
14601 KETTLE COVER (NEW STYLE)
14602 COVER CENTER & NUT
14947 CLIP - MOTOR DRIVE
16550 COVER CENTER & NUT-FIXED
16613 COVER CENTER & NUT-16 DIA PAN-7/8" HEX
16614 KETTLE COVER-DI 48/60 OZ.-9/16" HOLE

*C. CRETORS AND COMPANY
3243 N. CALIFORNIA AVENUE
CHICAGO, IL 60618*

*PHONE: (773)588-1690, (800)228-1885, FAX: (773)588-2171
WEB SITE: [Http://www.cretor.com](http://www.cretor.com) Email: postmaster@cretors.com*

**48/60 OZ. DIP
KETTLE AND OPTIONAL SS KETTLE**

(Shown "Upside-Down")
Beginning Serial number 1005

Di200027

DI48/60-C/D/E/G-2.0-B
05/10

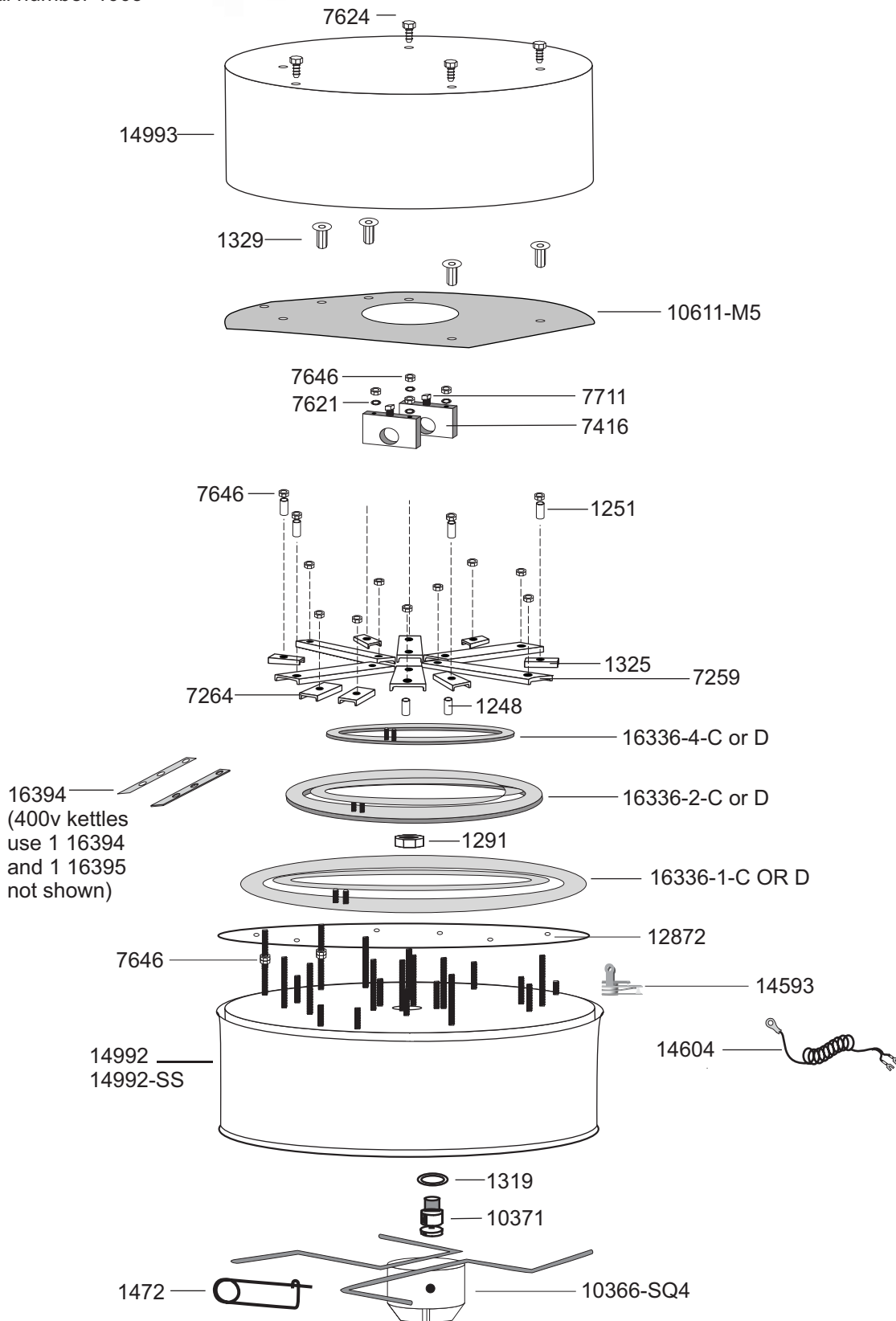

**48/60 OZ. DIPLOMAT
KETTLE AND OPTIONAL SS KETTLE**

DI200027

Di48/60-C/D/E/G-2.0-B
05/10

(Shown "Upside-Down") Beginning Serial No. 1005

1248	SPACER-1/4 x 1/2 (BAFFLE PLATE)
1251	5/8 " SPACER
1291	CENTER STUD LOCKNUT
1319	PAN CENTER WASHER
1329	RETAINER HEX SPACER
1325	ELEMENT CLAMP 3-1/4" (5 used)
1472	STIRRER BLADE RETAINING SPRING
7259	ELEMENT CLAMP 5-1/4" (6 used)
7264	ELEMENT CLAMP 5-1/4" (2 used)
7416	PAN MOUNTING BLOCK
7621	1/4" INTERNAL TOOTH LOCKWASHER
7624	1/4-28 x 1/2" HEX CAP
7646	1/4-28 HEX NUT
7711	5/16-18 x 1/2" SQUARE HEAD SCREW
10366-SQ4	STIRRER BLADE ASSEMBLY
10371	PAN CENTER
10611-M5	BAFFLE PLATE
12872	DIFFUSER PLATE
14593	HIGH LIMIT (LIMIT CONTROL)
14604	THERMOCOUPLE - RING TYPE - DIP
14992	POPPER PAN WITH STUD ASSY
14992-SS	POPPER PAN WITH STUD ASSY-STAINLESS STEEL
14993	RETAINER
16336-1-C	2000 WATT, 240 VOLT ELEMENT
16336-1-D	2000 WATT, 208 VOLT ELEMENT
16336-2-C	3050 WATT, 240 VOLT ELEMENT
16336-2-D	3050 WATT, 208 VOLT ELEMENT
16336-4-C	750 WATT, 240 VOLT ELEMENT
16336-4-D	750 WATT, 208 VOLT ELEMENT
16394	NICKEL STRAP--M5
16395	KETTLE ELEMENT JUMPER - 400V ONLY

* STAINLESS STEEL OPTION PARTS

TWIN DIPLOMAT 48/60 OZ - BACK VIEW
BEGINNING SERIAL No. 99064786

DOC: TDI30004

TDI48/60-A/E-3.0-A

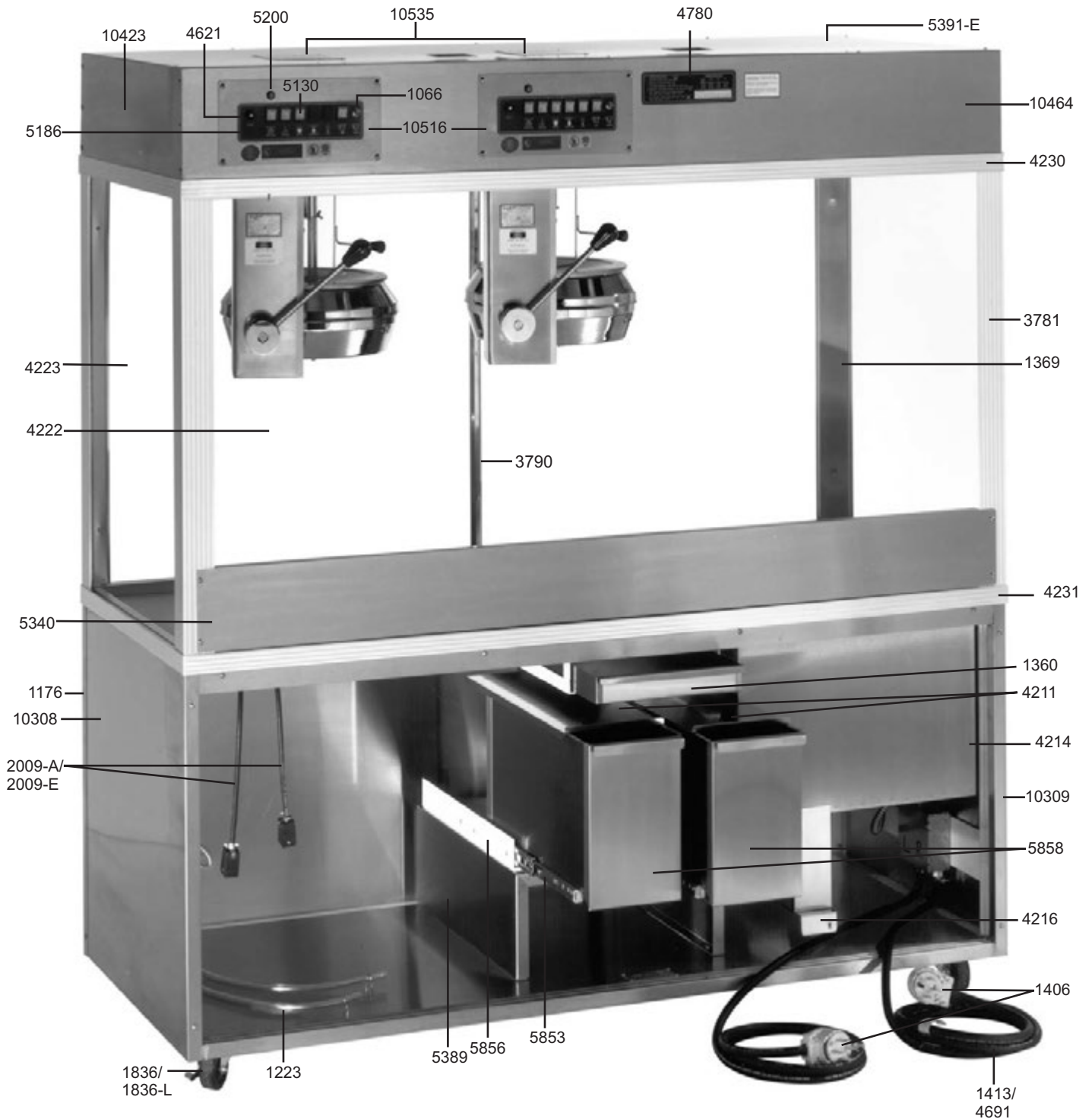

C. CRETORS AND COMPANY
176 MITTEL DRIVE
WOOD DALE, IL 60191

PHONE: (847)616-6900, (800)228-1885, FAX: (847)616-6970

WEB SITE: <http://www.cretors.com>

TWIN DIPLOMAT 48/60 OZ - BACK VIEW

DOC: TDI30004

TDI48/60-A/E-3.0-A

BEGINNING SERIAL No. 99064786

1066	SWITCH-PUSH BUTTON	5393-L	SLIDING DOOR-LEFT-TDI
1176	CORNER BASE TRIM-FRONT-PR/EPR/T	5393-R	SLIDING DOOR-RIGHT-TDI
1223	TUBING-NALGENE-CLEAR PER FOOT	5853	DRAWER SLIDE - PAIR
1360	CLEAN OUT DRAWER	5856	CORN DRAWER SLIDE
1369	INSIDE CORNER (FRONT) -ENCL PRES	5858	50# CORN DRAWER-NARROW
1370	INSIDE CORNER (REAR) -ENCL PRES	10491	RISER TUBE - TDI
1406	PLUG-50AMP, 125/ 250V, R, 4-WIRE	10516	SWITCHPLATE - 5' /6' DIPLOMAT120
1407	RECEPTACLE-50A 4-WIRE,NEMA 14	10552	DISCHARGE TUBE - TID
1413	CORN-30AMP, 1-4, SO		<u>TOP ASSEMBLY</u>
1757	CHANNEL-GLASS "U" SOLD PER FOOT	10423	TOP SHELL - SIDE-28" WIDTH
1836	CASTER -WITHOUT BRAKE	10464	TOP SHELL - BLANK PANEL - TDI W/S
1836-1	CASTER WITH BRAKE	10535	TOP PANEL
2009-A	PUMP CORD & PLUG 120V		<u>HARDWARE FOR TOP ASSEMBLY</u>
2009-E	PUMP CORD & PLUG 230V	7642	8-32 x 3/8 SS TRUSS HEAD (12)
3781	EXTRUSION-EPR-CORNER-NEW STYLE	7756	RIVETS (4)
3790	CENTER GLASS HOLDER - EPR	7789	# 8 STAR LOCKWASHER (12)
4211	50# CORN DRAWER COVER-NARROW	10539	#6 x 3/8 PHIL TRUSS (14)
4214	CORN BIN-TEPR / TDI/ EPR48		<u>NOT SHOWN</u>
4216	FIN CLEAN OUT SLIDE-TEPR/ TDI/ 4	10816	100# CORN DRAWER COVER
4222	GLASS (FRONT) - TEPR/ TDI	12089	100# CORN DRAWER
4223	GLASS (SIDE) - TEPR/ TDI	12310	FUSE HOLDER-15A
4230	EXTRUSION-TEPR TOP	12311	FUSE 15 AMP
4231	EXTRUSION-TEPR BOTTOM		
4261	CIRCUIT BREAKER-120/ 15A-PUSH		
4691	CORD - 25 AMP-EXPORT - SOLD PER FOOT		
4780	DECAL-INSTRUCTION-20/ 32/ 48/60 OZ		
5130	SWITCH-LIGHTED-230V		
5186	DECAL-SWITCHPLATE-KIP-ROCKER S		
5200	INDICATOR LIGHT		
5340	CORN GUARD-TDI TEPR W/ O BF		
5389	DRAWER MOUNT-TDI		
5392	SLIDING DOOR-CENTER-TDI		

C. CRETORS AND COMPANY

176 MITTEL DRIVE

WOOD DALE, IL 60191

PHONE: (847)616-6900, (800)228-1885, FAX: (847)616-6970

WEB SITE: <http://www.cretors.com>

DIP/M5/MA KETTLE SUPPORT COLUMN
20/32/48/60 OZ.

DOC: Di200022

DI-20/32-E/H-2.0-C
06/06

BEGINNING SERIAL: 0606

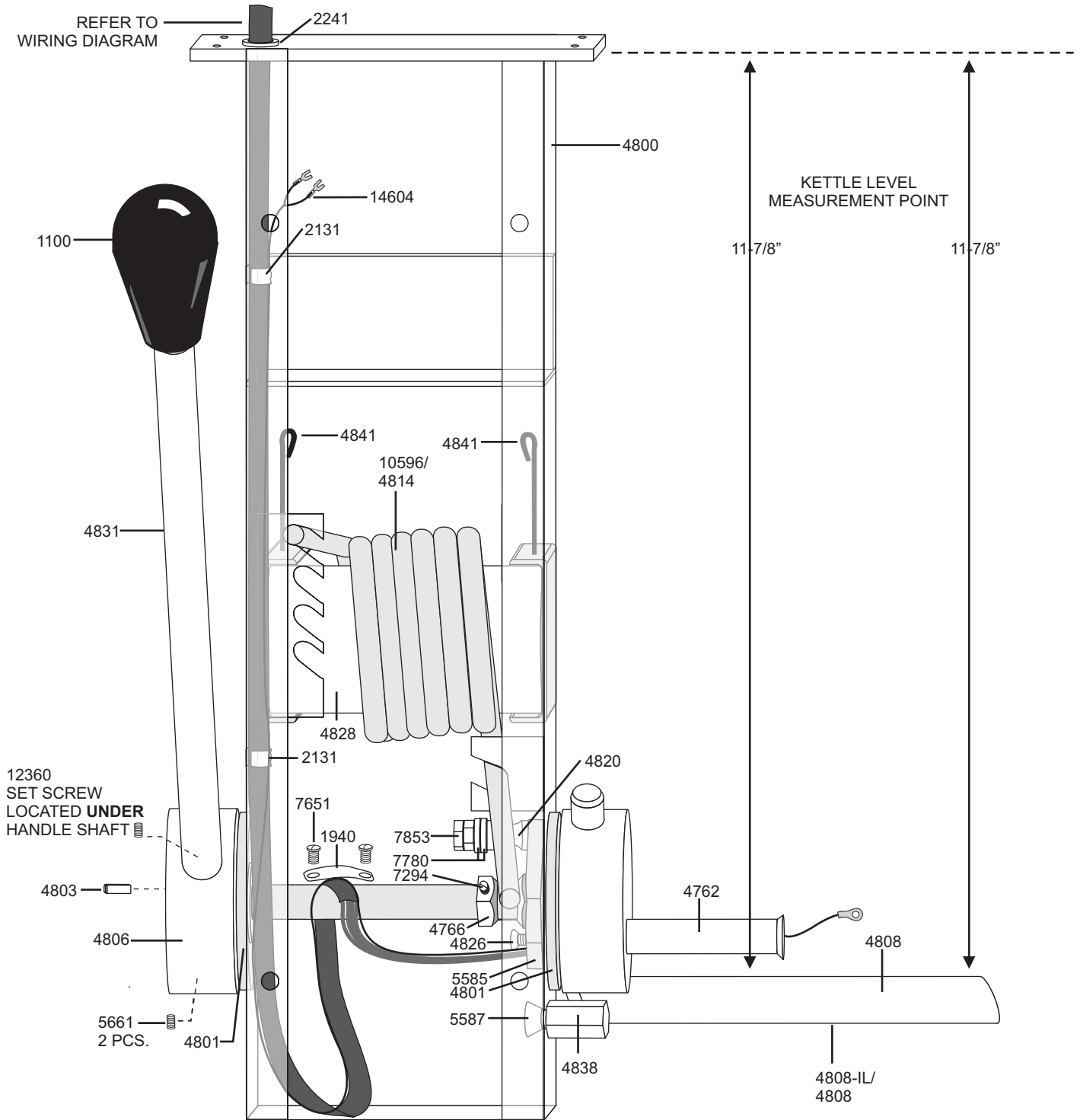

**DIP/M5/MA KETTLE SUPPORT COLUMN
20/32/48/60 OZ.**

DOC: Di200022

DI-20/32-E/H-2.0-C
06/06

BEGINNING SERIAL: 0606

1100	KNOB
1940	WIRE CLAMP FOR DIPLOMAT
2131	PIPE CLAMP #125
2241	1/2" INSULINER SLEEVE
4762	WIRE GUIDE TUBE
4766	KETTLE LEVEL NUT
4800	SUPPORT COLUMN - SPRING DUMP
4801	BEARING - COLUMN SUPPORT
4803	KEY - DIPLOMAT SPRING DUMP
4806	HANDLE HUB
4807	SUPPORT COLUMN COVER PLATE (NOT SHOWN)
4808	ECCENTRIC - DIP SPRING RETURN
4808-IL	ECCENTRIC - M5 SPRING RETURN
4814	RETURN SPRING (DI 20/32 OZ)
4820	ROLLER AND BEARING
4826	ARM BOLT 5/16-18 X 1
4828	SPRING HOLDER TUBE
4831	DUMP HANDLE - SPRING DUMP
4838	STOP BLOCK
4841	COTTER PIN 1/8 X 2
5585	SPRING ADJUSTMENT ARM
5587	3/8-16 X 3/4 FH SOCKET CAP
5661	5/16-18 X 1/2 SET SCREW
7294	10-32 X 3/16 SET SCREW, BRASS TIP
7651	10-24 X 1/2 B.H
7780	5/16 FLAT WASHER
7853	5/16-24 HEX NUT
10596	RETURN SPRING (DI48/60 OZ) M5 32/48/60
12360	1/2-20 X 3/8" SOCKET SET SCREW - UNDER 4831
14604	THERMOCOUPLE-RING TYPE-DIPLMAT

48/60 OZ. DIPLOMAT

BOTTOM VIEW - LOOKING DOWN ON PAN
BEGINNING SERIAL: 0604

DOC: DI200020

DI48-C/D-2.0-B
03/06

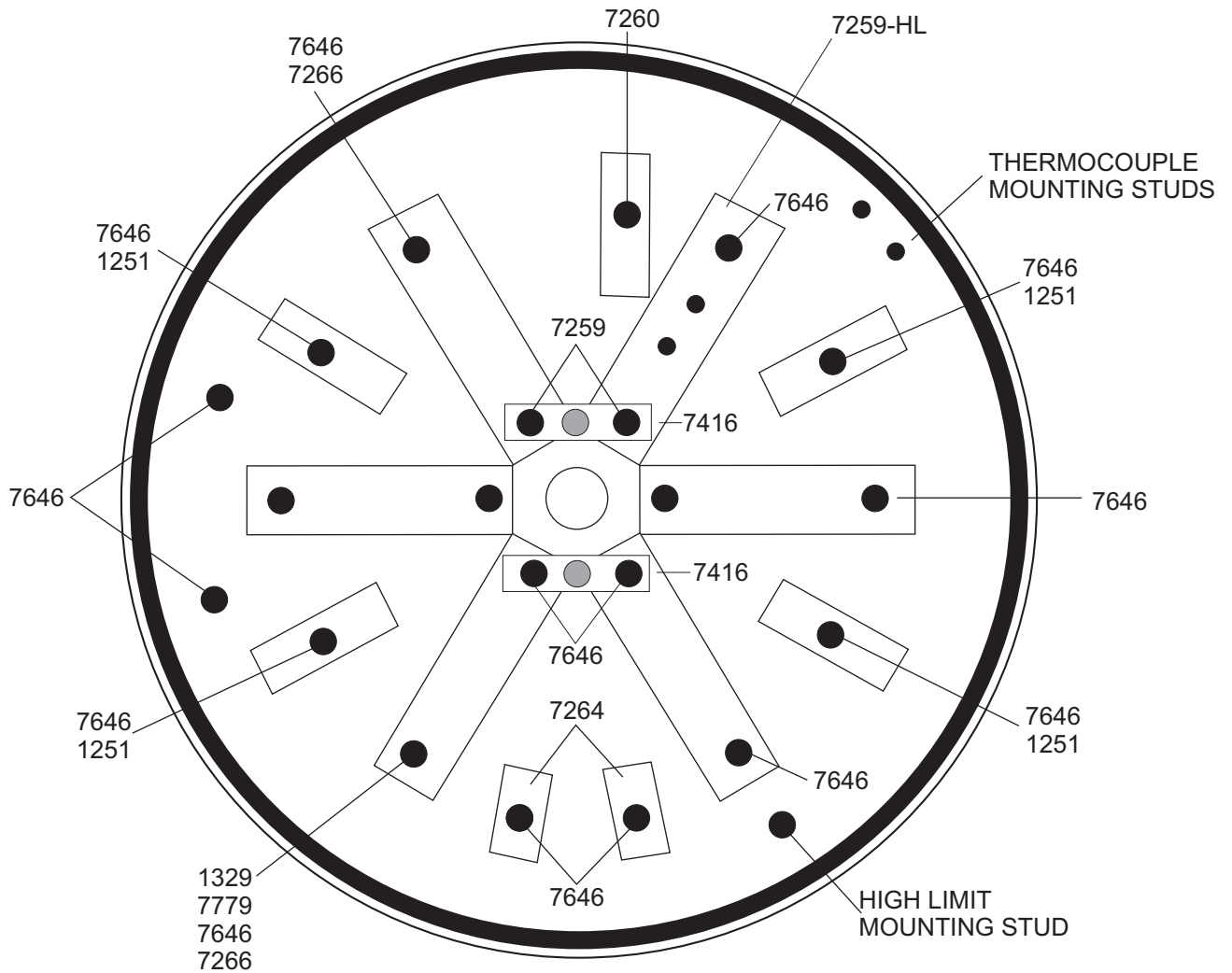

1251	SPACER - 1/4" x 5/8"	7264	ELEMENT CLAMP - 1-5/8"
1329	RETAINER HEX SPACER	7266	SPACER - 1/4" x 3/4"
7259	ELEMENT CLAMP - 5-1/4"	7646	1/4-28 HEX NUT
7259-HL	ELEMENT CLAMP - 5-1/4" HIGH LIMIT	7779	1/4" SAE FLAT WASHER
7260	ELEMENT CLAMP - 3-1/4"		

DIPLOMAT 48/60 OZ - TOP VIEW
ONE POP- SALT SUGAR OPTION (NOT SHOWN)
 BEGINNING SERIAL 00050000

DOC: DI300024

DI48/60-A/E-3.2-B
 07/04

ONE POP-SALT SUGAR- OPTION- NOT SHOWN

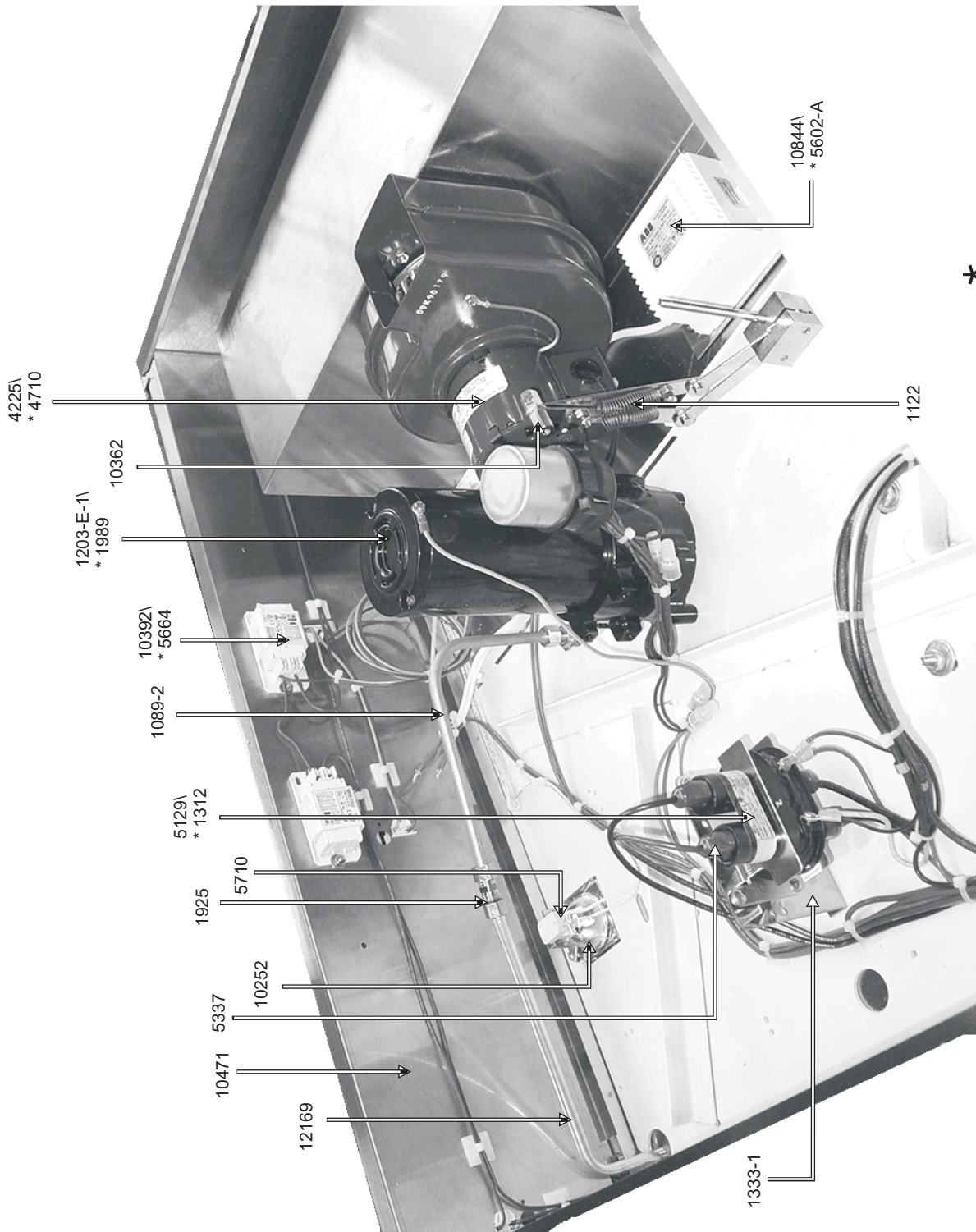

* DOMESTIC

DIPLOMAT 48/60 OZ - TOP VIEW
ONE POP- SALT SUGAR OPTION (NOT SHOWN)

DOC: DI300024

DI48/60-A/E-3.2-B
07/04

BEGINNING SERIAL 00050000

1089-2 DISCHARGE TUBE TOP
1122 SPRING TRIP ARM (2)
1203-E-1 MOTOR-EXPORT
1312 RELAY-120V
1333-1 BRACKET - RELAY MOUNTING
1925 DISCHARGE TUBE COUPLING
1989 MOTOR
4225 BLOWER (230V)
4710 BLOWER(120V)
5129 RELAY- 240 V
5337 VINYL CAP (2)
5664 BALLAST
5710 SOCKET HALOGEN
10252 LAMP HALOGEN (4)
10362 AUTOMATIC COVER LIFT - 48OZ DIPLOMAT
10392 BALLAST-230V (2)
10471 TOP SHELL - SSTS PANEL - DIPLOMAT
10844 TRANSFORMER
12169 RISER TUBE - DI48

NOT SHOWN

5103 SOCKET 450 W - 1 -A (4)
5104 LAMP FLOURESCENT F13T5/CW (2)
10487 SIGN - POPCORN - RED AND YELLOW (1)
10632 SIGN BACKING FOR PN 10487

* DOMESTIC

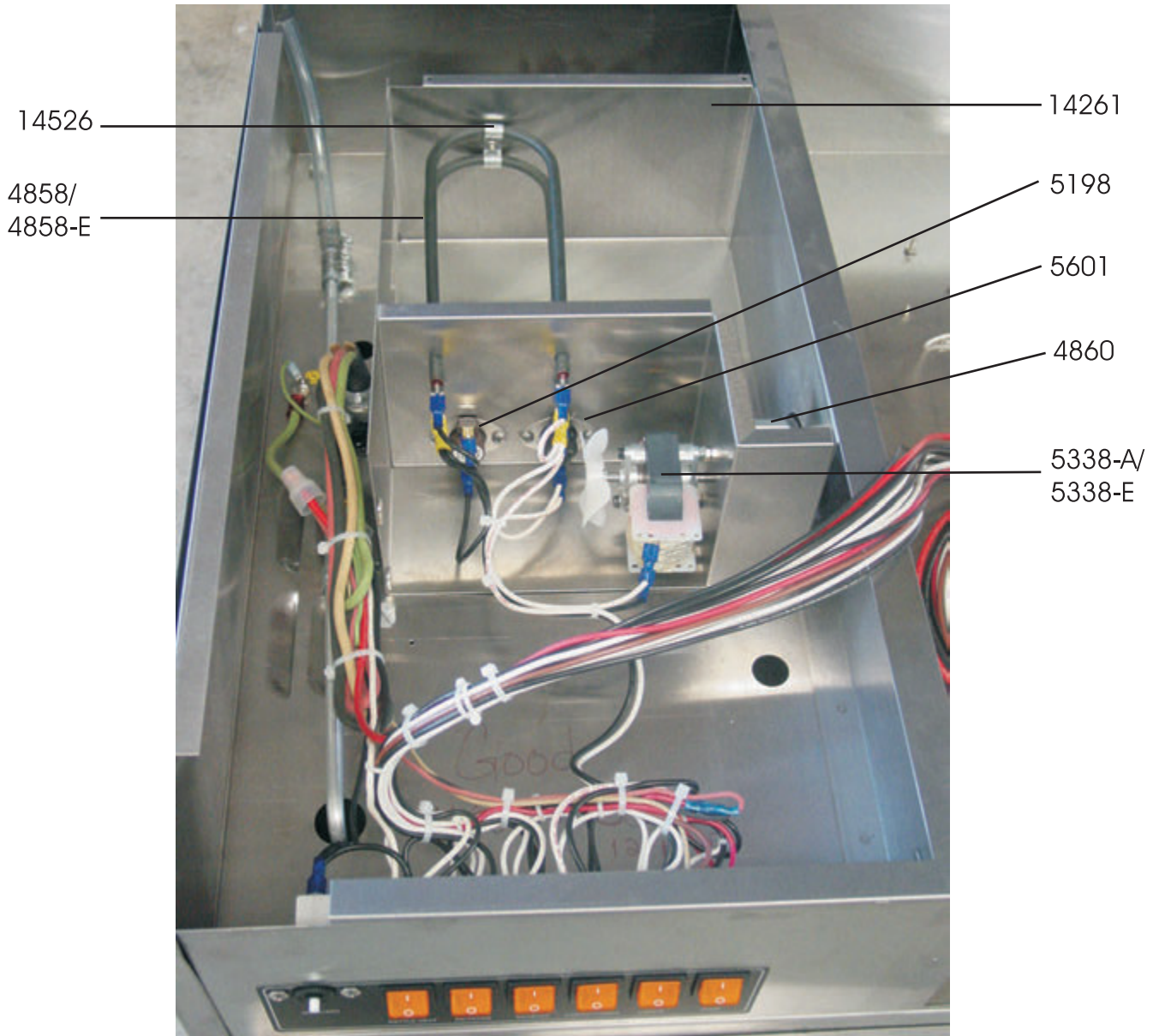

- | | | |
|--------|-------------------------------------|--------------------|
| 5198 | THERMOSTAT | 5201-2-A |
| 5601 | HIGH LIMIT - 200 DEGREES FAHRENHEIT | CORNDITIONER ASSY- |
| 5338-A | MOTOR BLOWER - 120V | REMOVABLE - 120V |
| 5338-E | MOTOR BLOWER - 230V | |
| 4858 | ELEMENT CORNDITIONER - 400W - 120V | 5201-2-E |
| 4858-E | ELEMENT CORNDITIONER - 400W - 230V | CORNDITIONER ASSY- |
| 4860 | BLOWER WHEEL | REMOVABLE - 230V |
| 14261 | CORNDITIONER BOX | |
| 14526 | CLAMP - DUAL 3/8 BX | |

MACH 5 & DIPLOMAT 48/60 OZ

AGITATOR DRIVE SYSTEM

BEGINNING SERIAL: 1807

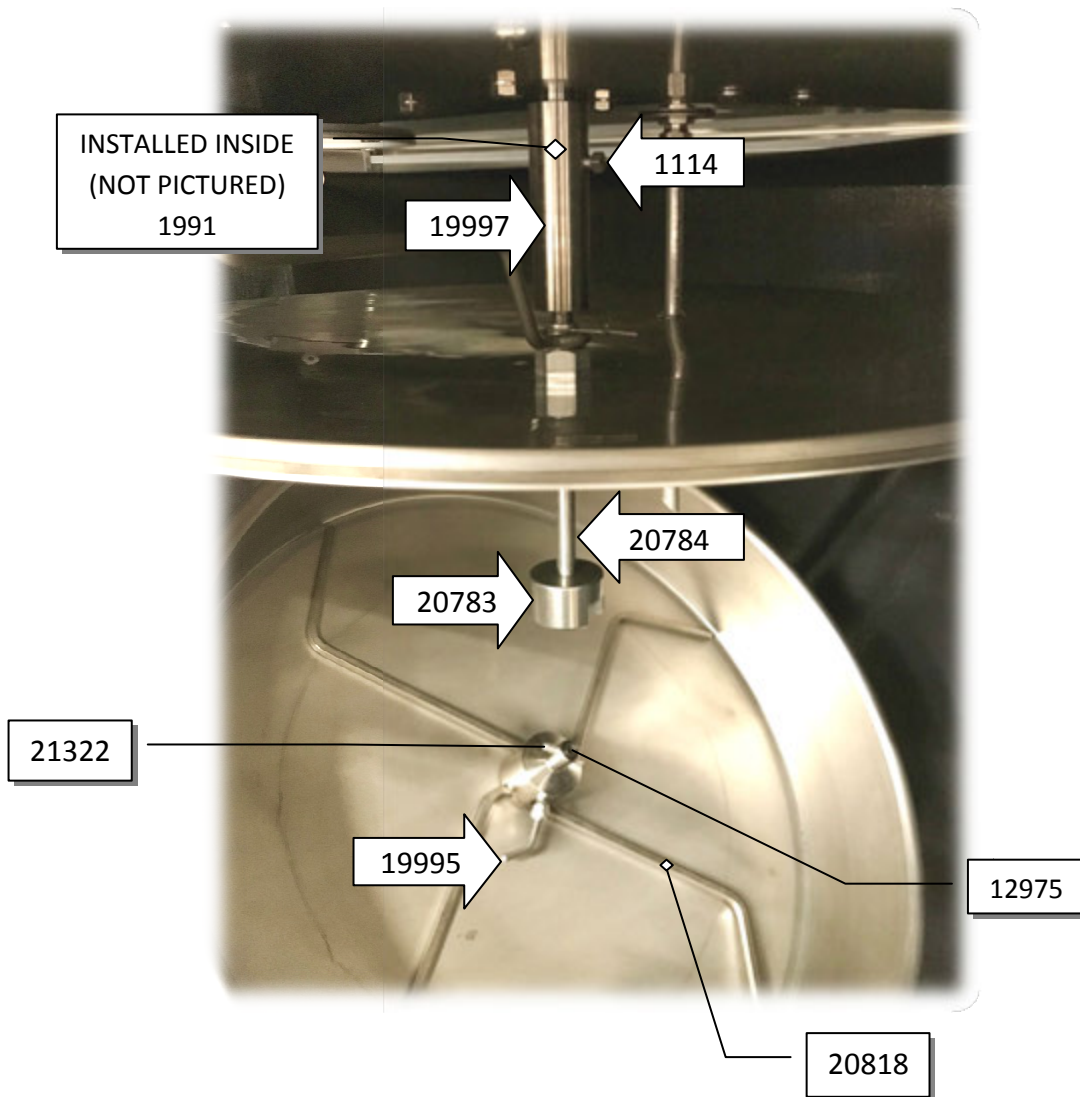

PART NUMBER	DESCRIPTION	QUANTITY
1991	SPRING, 0.125" PITCH, 0.036" WIRE DIAMETER	1
1114	1/4-20 X 3/8"LG, SQ HD SET SCREW, CUP POINT, 18-8 S.S.	1
19997	SHAFT CONNECTOR	1
20784	DRIVE SHAFT, M5/DI, 16" KETTLE	1
20783	CLUTCH DOG, M5/DI, 16" KETTLE	1
21322	3/16"DIA X 1"LG, GROOVED PIN, 18-8 S.S.	1
12975	1/4-28 X 3/16"LG, SOCKET SET SCREW, CUP POINT, ALLOY PLAIN	1
20818	STIRRER BLADE WELDMENT, M5/DI, 16" KETTLE	1
19995	RETAINING PIN, STIRRER BLADE	1

C. CRETORS AND COMPANY
 176 MITTEL DRIVE
 WOOD DALE, IL 60191
 PHONE: (847) 616-6900, (800) 228-1885
 FAX: (847) 616-6970
 WEBSITE: WWW.CRETORS.COM
 EMAIL: POSTMASTER@CRETORS.COM

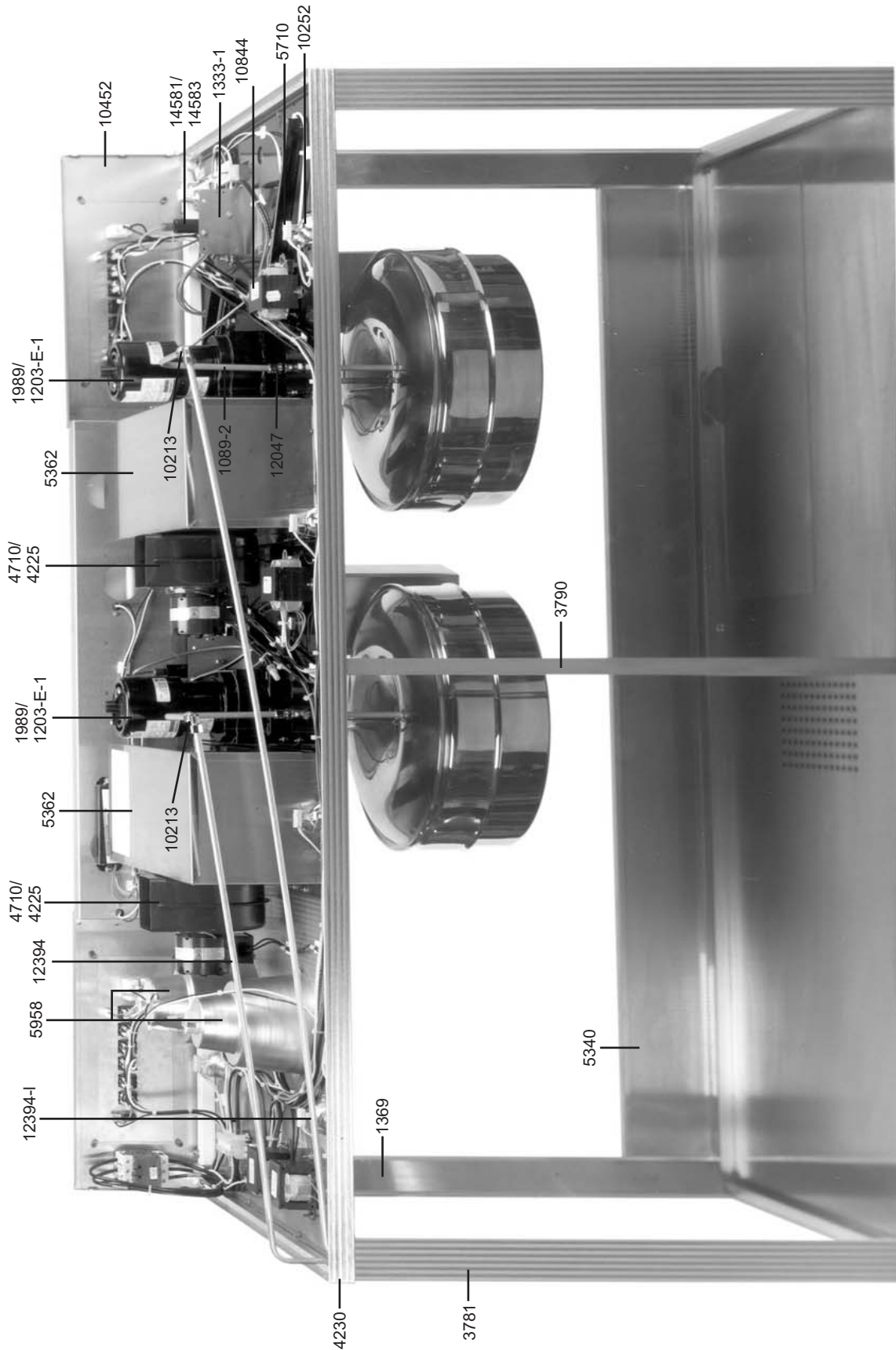

1089-2 DISCHARGE TUBE TOP
1203-E-1 MOTOR 230V
1369 INSIDE CORNER (FRONT)-ENCL PRES
1989 MOTOR 120V
3790 CENTER GLASS HOLDER EPR
4225 BLOWER-230V(2C916)
4230 EXTRUSION TEPR TOP
4710 BLOWER-120V (1C982B)
5340 CORN GUARD-TDI & TEPR W/O BF
5362 FILTER HOUSING TDI/5"DIP
5710 SOCKET-HALOGEN
5958 LAMP GUARD- SPUN
10213 COUPLING-RIGHT ANGLE
10252 LAMP-HALOGEN
10452 TOP SHELL-SSTS PANEL-TDI W/S
10844 TRANSFORMER 100W, 120/230V-12V,
VDE
14581 RELAY-120V.-SINGLE POLE
14583 RELAY-230V.-SINGLE POLE