



---

**176 MITTEL DRIVE, WOOD DALE, IL 60191**

---

# **DIGITAL GIANT POPCORN MACHINE OPERATION MANUAL**

**120/208 Volt,  
Single and Three Phase, 60 Hz**

**120/240 Volt,  
Single and Three Phase, 60 Hz**

**230 Volt,  
Single Phase, 50 Hz**

**400 Volt,  
Three Phase, 50 Hz.**

**100/200 Volt  
Single Phase, 50/60 Hz**

**Included in this manual:**

- \*One Pop Option**
- \*Salt/Sugar Option**



**READ and UNDERSTAND these operating and safety instructions before operating this popcorn machine!**

---

**TABLE OF CONTENTS**

I. Safety Alert Symbol ..... 3

II. Safety First ..... 3

III. Introduction ..... 3

IV. Purpose of Manual ..... 4

V. Product Identification ..... 4

VI. Principles of Popcorn Machine Operation ..... 5

VII. Control Switches ..... 6

VIII. Operating Instructions ..... 7

IX. Sanitation Instructions ..... 9

    A. Popping Kettle

    B. Kettle Cover and Agitator Removal ..... 10

    C. Giant Popping Plants ..... 10

---

## I. SAFETY ALERT SYMBOL

The symbol shown is used to call your attention to instructions concerning your personal safety and the safety of others. Watch for this symbol. It points out important safety precautions. It means **ATTENTION! Become Alert! Your personal safety is involved!** Read the message that follows and be alert to the risk of personal injury or death.



---

## II. SAFETY FIRST



The information in this manual is essential for the safe installation and operation of your Cretors popcorn machine. The manual must be read and understood before installing, and operating the equipment, or equivalent training must be provided.



“The employer shall instruct each employee in the recognition and avoidance of unsafe conditions, as well as, the regulations applicable to his work environment and to control or eliminate any hazards or other exposure to illness or injury”. Ref.: 29 CFR 1926.20 (b)(4)(a)(2)



It is understood that safety rules within individual companies vary. If a conflict exists between the safety procedures contained in this manual and the rules of a using company, the more stringent rule should take precedence.

---

## III. INTRODUCTION

This manual is filled with time-saving and money-saving information regarding your Cretors popcorn machine. There is nothing more important than the safety aids and warnings that are throughout this document. The Safety Alert Symbol is used to identify topics of primary safety concern wherever they appear. Furthermore, a separate section has been included which deals exclusively with service and accident prevention.

If, after reviewing this manual, anything is unclear or technical problems are encountered, contact the distributor from whom you purchased your machine for assistance. If there are any additional questions, feel free to contact our Customer Service Department at the address and/ or phone number listed on the last page of this manual. Always have the model and serial number of your machine available to assist in obtaining the correct information.

**IV. PURPOSE OF MANUAL**

This instruction manual is intended to familiarize owners with the operation and safety procedures associated with your Cretors popcorn machine.

It is important that this manual be kept available to operating personnel.



A person who has not read and understood all operating and safety instructions is not qualified to operate the machine.

**V. PRODUCT IDENTIFICATION**

<u>Model</u>	<u>Kettle</u>	<u>Voltage</u>	<u>Corn</u>	<u>Control</u>	<u>Hand</u>	<u>Features</u>
<b>EG -- Electric Giant</b>						
20	-- 20 Oz. Kettle					
32	-- 32 Oz. Kettle					
48	-- 48 Oz. Kettle (Not available in Stainless Steel)					
60	-- 60 Oz. Stainless Steel Kettle					
<b>60Hz. (North America)</b>						
C	-- 120/240/1/60					
D	-- 120/208/1/60					
Q	-- 120/208/3/60					
R	-- 230/1/60					
<b>50 Hz.</b>						
E	-- 230/1/50					
G	-- 400v 3N / 50 CE					
N	-- 240/415/3/50					
<b>Japan</b>						
I	-- 100/200/1/50					
J	-- 100/200/1/60					
P	-- 100/200/3/60					
<b>1 -- Salted Corn</b>						
<b>2 -- Sugar Corn</b>						
<b>3 -- Salt &amp; Sugar Corn (Order Salt / Sugar Pump)</b>						
<b>X -- Standard Control</b>						
<b>O -- One Pop Control</b>						
<b>C -- One Pop with Counter</b>						
<b>D -- SS Pan Pedestal 0.4</b>						
<b>E -- Digital Control -0.5</b>						
<b>F -- Digital One Pop 0.68</b>						
<b>R</b>						
<b>L</b>						
<b>EG</b>						
<u>Model</u>	<u>Kettle</u>	<u>Voltage</u>	<u>Corn</u>	<u>Control</u>	<u>Hand</u>	<u>Features</u>
						<b>X -- No Custom Features</b>
						<b>C -- Custom Features</b>
						<b>X -- Not Equiped for Pump</b>
						<b>O -- OEM Package</b>
						<b>F -- Fan Control</b>
						<b>D -- Dual Control</b>
						<b>SS -- Stainless Steel 32 Oz.</b>
						<b>Z</b>

---

## VI. PRINCIPLES OF POPCORN MACHINE OPERATION

### Theory and Observations of Popcorn Machine Operation

- A. The efficient production of popcorn requires the presence of popcorn kernels, heat, and oil. The purpose of the oil is to distribute the heat throughout kernels evenly and quickly. If the heat is not distributed evenly and quickly, the kernels may burn instead of pop.
- B. In order to pop corn in oil, the kettle, oil and parts near the heating elements are necessarily and unavoidably heated to temperatures high enough to pop popcorn. The temperature is controlled using a digital temperature control located inside the kettle to maintain the kettle at an operating temperature of approximately:

400-410°F (204-210°C) for salted corn  
375-385°F (190-195°C) for sugar corn



Contact with these surfaces will burn and scald you. Do not touch the kettle, oil or parts in direct vicinity of the heating elements.

- C. The kettle is provided with an agitator to assist in the quick and even distribution of heat throughout the kernels.



The oil is heated to high temperatures in a kettle provided with electric heating elements to reach a proper popping temperature. An operator is required in the vicinity of the kettle only when handling corn or dumping popped corn from the kettle. Neither of these operations requires direct contact with the kettle. Direct contact with the hot oil, kettle, or heating elements could result in serious burns or scalds. Keep away from the kettle whenever possible. Use the handle when dumping the kettle, and use the provided cups to measure corn, oil and salt.

- D. As the popcorn pops, it will push the lid open and discharge into the cabinet. When the corn finishes popping, the corn remaining in the kettle can be removed by holding the kettle handle in your right hand and rotating upwards in a counter-clockwise direction to dump the kettle. Return kettle to level position when finished.
- E. Your Giant Model Cretors popcorn popper maybe equipped for a pump, which, when properly adjusted, automatically delivers the proper amount of oil to the popping kettle.
- F. OEM models are provided with a short cord and plug and have a flexible armored cable with wires connected to the 'cornditioner' switch on the switch panel.
- G. One Pop Option only allows the kettle to pop one batch of corn at a time and then shut down. The One Pop Option makes it impossible to leave a kettle heat turned on.

- H. With the One Pop Option, the kettle heat switch is turned on; however, the kettle will not begin to heat until the One Pop button is pressed. When the One Pop button is pressed the green indicator light will go on, the kettle will begin to heat, and the kettle heat indicator light will turn on. The kettle will then heat until the temperature control opens at the end of the popping cycle. When the temperature control opens at the end of the popping cycle the kettle heat indicator light goes out and the heat turns off. The kettle will not begin to heat again until the kettle has cooled and the One Pop button is pressed.
- I. If the machine is equipped with an oil pump, and the pump switch is turned on, pressing the One Pop button will begin the pumping cycle, as well as, the heat cycle. (When cleaning the kettle and oil is not wanted, turn off the oil switch and the oil pump will not run.)
- J. If the machine is equipped with the Salt/ Sugar option, the operator moves the toggle switch to either the salt or sugar position for desired corn type. Kettle temperature and oil amount will change automatically. In the salt position, the thermostat will turn off at the sugar temperature but a timer will allow the heat to remain on until it reaches the salt temperature.

---

**VII. CONTROL SWITCHES (Not all machines contain all of these switches.)**

KETTLE HEAT	-Turns the kettle heat On/ Off.
AGITATOR	-Turns the stirrer blade motor On/ Off. (Only export machine must have motor switch on to turn low heat)
EXHAUST	-Turns exhaust blower On/ Off.
CORNDITIONER	-Turns the cornditioner blower and heat On/ Off.
LIGHTS	-Turns interior lights On/ Off.
OIL	-Provides power to the oil pump.
DELIVERY	-Initiates the pump cycle.
FUSE/ CIRCUIT BREAKER	-Provides protection to all circuits, except the kettle.
ROTARY SWITCH	-Turns power On/ Off to all circuits.
ONE POP	-Turns the kettle heat on and initiates pump cycle.
SALT/ SUGAR	-Sets the pump and kettle temperature to proper settings.
DIGITAL CONTROLLER	- Displays and controls kettle temperature.

---

## VIII. OPERATING INSTRUCTIONS



Do not attempt to operate your Cretors popcorn machine until you have read and understood this manual. Failure to do so may result in serious injury or death.



Do not attempt to operate your Cretors popcorn machine unless the installation instructions have been strictly adhered to. Failure to do so may result in serious injury or death.



Operate your popcorn machine only if it is in good sanitary condition (See **SANITATION INSTRUCTIONS**). Failure to do so may result in illness to your customers.



Always turn the kettle heat switch off when not popping corn. Failure to do so will cause oil to stain the kettle, possibly resulting in an unsanitary condition. It may also cause a “flash” fire if oil is added to a kettle left unattended with the heat on, resulting in serious burns or death.

A. To operate your Cretors popcorn popping machine:

1. Connect and adjust the pump as explained in the pump installation instructions and pre-heat the popping oil until liquid, if necessary.
2. Fill the corn measure with corn and the salt measure with the salt, and empty these into the kettle. When making sugar corn, add the correct amount of sugar, rather than salt, with the measure for corn.



**WARNING!** Always add corn to the kettle before pressing the oil delivery button or adding oil. Failure to do so may result in the oil being heated too rapidly resulting in a fire.



Avoid contact with the kettle. Contact with a hot popping kettle may result in serious burns or scalds.

3. Rotate the kettle lid closed by using the counter weight as a handle.
4. If equipped, move Salt/ Sugar switch to desired mode.
5. Turn on the agitator, the exhaust fan, and then turn on the kettle heat and press the oil delivery button.
6. If machine is with the One Pop option, press the One Pop button to begin the popping cycle, and oil delivery.



**WARNING!** After the first popping the kettle is hot. Avoid contact with the kettle when adding corn or salt. Failure to do so may result in serious burns or scalds.

Measuring cups have been provided to accurately measure the proper amounts of popcorn, salt and oil. The correct amount for each popping is:

### SALTED CORN

<u>Kettle Size</u>	<u>VOLUMETRIC MEASURE</u>		
	<u>Corn</u>	<u>Oil</u>	<u>Salt</u>
20 oz.	20 oz. 591 ml	6.5 oz. 192 ml	2 tsp. 10 ml
32 oz.	32 oz. 1083 ml	12.25 oz. 360 ml	3 tsp. 15 ml
48 oz.	48 oz. 1420 ml	16.5 oz. 492 ml	4 tsp. 20 ml
60 oz.	60 oz. 1774 ml	20 oz. 591 ml	5 tsp. 25 ml

### SUGAR CORN

<u>Kettle</u>	<u>VOLUMETRIC MEASURE</u>		
	<u>Corn</u>	<u>Oil</u>	<u>Sugar</u>
20 oz.	12 oz. 351 ml	4.25 oz. 122 ml	8.25 oz. 245 ml
32 oz.	19.5 oz. 577 ml	7.5 oz. 225 ml	15.25 oz. 451 ml
48 oz.	28.7 oz. 850 ml	10.5 oz. 310 ml	20.75 oz. 614 ml
60 oz.	48 oz. 850 ml	16.5 oz. 492 ml	26 oz. 770 ml

- As the corn pops, it will push the lid open. When the lid has moved about one and one-half inches, it will open completely, allowing the corn to discharge from the kettle. When the corn finishes popping (when there are about four seconds between pops) dump the kettle by lifting the large black handle up and rotate as far as it will go. When the pan is empty, return the handle to its upright position.



Avoid contact with the kettle when dumping popped corn. Failure to do so may result in serious burns or scalds.

- Repeat steps 2-7 to continue popping. When finished, turn kettle heat switch off.
- When the oil container is empty, replace with a new full container of oil. See Pump Instruction manual.

**NOTE:** The ideal time for maximum volume (corn expansion) is between 2-3/ 4 to 3-1/ 2 minutes from the time the corn is placed into the kettle until the time it is dumped. Check the popping time after several popping cycles. The pilot light should turn off approximately 10-20 seconds before the corn finishes popping. If this is not the case, please refer to the Trouble Shooting Section in your Service Manual.

---

## IX. SANITATION INSTRUCTIONS





Be certain the machine is turned off and power is unplugged before sanitizing this machine unless a specific cleaning procedure requires power to the machine. Failure to do so could result in injury or death.



Do not clean heated surfaces until they have been given sufficient time to cool. Failure to do so may result in serious burns or scalds.

### A. Popping Kettle

1. The Cretors kettle is designed to be cleaned in place. There is no need to remove the kettle to clean.



Do not immerse an assembled kettle in water. This will damage the electrical components and may cause short circuits resulting in electrical shock hazard if power is applied.

2. Do not use steel wool or other similar abrasives to clean the nickel plated kettles, as they will ruin the kettle by removing the nickel plating. Stainless steel kettles can be cleaned aggressively.
3. Do not clean the kettle with power connected unless you are boiling the CKC cleaning compound to clean the inside of the kettle. Follow instructions in step 6.
4. The kettle either has a polished nickel finish or is a polished stainless steel finish and is very easy to clean if oil is not allowed to burn. After the final popping, the best practice is to wait until the oil just begins to solidify, then take a cotton towel or absorbent rag and wipe the kettle. Once the oil is allowed to completely solidify, it can become more difficult to remove. We recommend coconut oil for your Cretors popper; it will not stick or burn as easily as other oils.
5. A thorough cleaning every week with CKC cleaning compound is recommended. This will prevent the accumulation of carbon on the bottom and internal sides of the kettle. When boiling the CKC cleaning compound in the kettle, do not fill the kettle with more than  $\frac{3}{4}$ " high of water inside the kettle. If the kettle has been overheated or oils that tend to carbonize are used the normal cleaning procedures may not suffice. Increase frequency as needed.

Cretors has developed a cleaning kit for your Giant machine. The kit is sold separately under P/ N 10837. If you need more information, please feel free to contact your local distributor or call Cretors at 1-800-228-1885.

6. Cretors Outside Kettle Cleaner COC should be used periodically to remove popping oil that may become baked on to the outside of the kettle.
7. The kettle agitator assembly should be removed weekly for thorough cleaning. The stirrer blade is disassembled by removing the spring pin that goes through the top of the stirrer blade. Lift off the stirrer blade.

8. Clean all parts thoroughly, making sure to use CKC. Do not use any harsh abrasives or cleaning materials.
9. There are two new Cretors cleaners. Carbon OFF in the blue can is to be used with no heat. The red can would require the kettle to be heated. Read the directions on the cans.
10. Reassemble in reverse order, following the directions given.

### **B. Kettle Cover and Agitator Removal**

1. To remove the kettle cover, first remove the rear pin by rotating the loop of the pin so that the pin can be pulled out of the two kettle tabs. Next, remove the front pin by rotating the loop of the pin so that the pin can be pulled straight out of the hinges and apron. As the pin is pulled out, hold the front cover as it will fall off when the pin is removed. Lastly, lift off the rear cover and then the apron. To remove the apron, lift straight up where the tabs insert into the kettle, then pull the tabs out, one side at a time until the apron is fully disengaged from the kettle.
2. The agitator assembly is disassembled by removing the anti-pack pin going through the top of the stirrer blade. Lift off the stirrer blade. Place kettle in dump position and slide the clutch dog and shaft out from the bottom of the pan. (If shaft will not easily drop out, use a hammer and lightly tap on the shaft to break it free. If it is apparent that the clutch dog and shaft cannot be removed, leave it in place, however, at sometime in the future it will be necessary to remove and replace the entire pan center and clutch dog assembly. This must be done before the clutch dog shaft becomes hard to turn; when the shaft becomes hard to turn the agitator motor will be overloaded and damaged.)
3. Clean all parts thoroughly, making sure to use CKC. Do not use any harsh abrasives or cleaning material. Pay particular attention to the interior of the blade center. Some popping oils will carbonize and build up on the interior of the blade center and create a tight fit on the pan center. (Normal clearance is 1/ 8" -- 3 mm). When this happens oil will 'wick-up' the narrow gap and leak down the clutch dog shaft and give the appearance that the kettle is leaking oil. In extreme cases the carbon will cause the blade center to grip the pan center and turn it. This will loosen the pan center and a serious oil leak will occur. When reassembling lightly coat the clutch dog shaft with moly grease or a comparable high temperature lubricant.
4. Reassemble cover in reverse order, following the directions above.

### **C. Giant Popping Plants**

Remove and empty the waste clean-out drawer daily or whenever it is full. Under heavy use this may need to be done more often.

This appliance should not be cleaned with a water jet.

This manual is filled with time-saving and money-saving information regarding your Cretors popcorn popper. There is nothing, however, more important than the safety aids and warnings found throughout this document.

If you have any questions regarding the operation or cleaning of your Cretors popcorn popper, contact your local distributor. Should you have any difficulties or are unable to reach them, feel free to contact the Customer Service Department at C. Cretors and Company.

Additional copies of this manual can be obtained from C. Cretors and Company at the address listed below. Please provide the model and serial number when requesting additional copies of this manual. There will be a nominal charge for additional copies.

Cretors guarantees this machine to be free of defects in parts, materials and workmanship for two years. Please take this time to fill out the factory registration card and return it to the factory to activate your warranty. If you have any questions concerning the Cretors' warranty, please contact your local distributor or the Customer Service Department at C. Cretors and Company.



C. CRETORS AND COMPANY  
3243 N. CALIFORNIA AVENUE  
CHICAGO, IL 60618  
PHONE (773) 588-1690, (800) 228-1885, FAX (773) 588-2171  
WEB SITE: [http:// www.cretors.com](http://www.cretors.com) Email: [postmaster@cretors.com](mailto:postmaster@cretors.com)



We invented the popcorn machine  
THEN JUST KEPT GOING!

---

176 MITTEL DRIVE, WOOD DALE, IL 60191

---

# DIGITAL GIANT POPCORN MACHINE SERVICE MANUAL

120/208 Volt,  
Single and Three Phase, 60 Hz

120/240 Volt,  
Single and Three Phase, 60 Hz

230 Volt,  
Single Phase, 50/60 Hz

400 Volt,  
Three Phase, 50 Hz.

100/200 Volt  
Single Phase, 50/60 Hz

**Included in this manual:**

**\*One Pop Option**

**\*Salt/Sugar Option**



**READ and UNDERSTAND these operating and safety instructions before operating this popcorn machine!**

---

## TABLE OF CONTENTS

I.	Safety Alert Symbol .....	3
II.	Safety First .....	3
III.	Introduction .....	3
IV.	Specifications .....	4
	A. Electric Specifications	
	B. Size Specifications	
V.	Purpose of Manual. ....	5
VI.	Installation Instructions. ....	5
	A. Location	
	B. Power Supply	
	C. Connecting Machine to Power Supply	
	D. OEM Option Pedestals	
	E. Pump Installation & Timer Adjustment for Salt/Sugar Machines	
VII.	Service Instructions .....	7
	A. Parts	
	B. Kettle Temperature Control	
	1. Temperature Control	
	2. Digital Temperature Control Adjustment	
	3. Checking Temperature Control	
	4. Salt Timer Adjustment	
	5. Salt/Sugar With One Pop Adjustment	
	C. Kettle Removal	
	D. Kettle Installation	
	E. Kettle Spring Adjustment	
VIII.	Troubleshooting .....	12

---

## I. SAFETY ALERT SYMBOL

The symbol shown below is used to call your attention to instructions concerning your personal safety and the safety of others. Watch for this symbol. It points out important safety precautions and procedures. It means "**ATTENTION! Become Alert! Your personal safety is involved!**" Read the message that follows and be alert to the risk of personal injury or death.



---

## II. SAFETY FIRST



The information in this manual is essential for the safe installation and service of your Cretors popcorn machine. The manual must be read and understood before installing, or maintaining equipment, or equivalent training must be provided.



"The employer must instruct each employee in the recognition and avoidance of unsafe conditions, regulations applicable to his work environment to control or eliminate any hazards or other exposure to illness or injury". Ref.: 29 CFR 1926.20 (b)(4)(a)(2)



It is understood that safety rules within individual companies vary. If a conflict exists between the safety procedures contained in this manual and the rules of a using company, the more stringent rule should take precedence.

---

## III. INTRODUCTION

This manual is filled with time-saving and money-saving information regarding your Cretors popcorn machine. There is nothing, however, more important than the safety aids and warnings that are found throughout this document. The Safety Alert Symbol is used to identify topics of primary safety concern wherever they appear. A separate section has been included which deals exclusively with operation and accident prevention.

If, after reviewing this manual, anything is unclear or technical problems are encountered, contact the distributor from whom you purchased your machine. For assistance and if there are any additional questions, feel free to contact our Customer Service Department at the address and/or phone number listed on the last page of this manual. Always have the model and serial number of your machine available to assist in obtaining the correct information.

## IV. SPECIFICATIONS

### Giant Models: G20EP, G32EP, G48EP, G60EP

#### A. Electrical Specifications:

Giant Models are available in the following electrical configurations:

100/200 Volt, Single Phase, 60 Hz

120/208 Volt, 120/240 Volt, Single and Three Phase, 60 Hz

230 Volt, 230/380 Volts, Single and Three Phase, 50/60 Hz

#### B. Size Specifications:

MODEL G20EP	GIANT 20 OZ. ELECTRIC WITH PUMP
Capacity:	20 oz. All-Steel Kettle, 400 one-ounce servings per hour.
Wattage:	3800 watts
Dimensions:	10-5/8"D x 10-1/2"W x 27-1/2" H - - - - 27 cm D x 26 cm W x 70 cm H
Net Weight:	63 lbs. (28.6 kg)
	Available in Stainless Steel

MODEL G32EP	GIANT 32 OZ. ELECTRIC WITH PUMP
Capacity:	32 oz. All-Steel Kettle, 640 one-ounce servings per hour
Wattage:	5200 watts
Dimensions:	10-5/8"D x 10-1/2"W x 31-3/4" H - - - - 27 cm D x 26 cm W x 81 cm H
Net Weight:	74 lbs. (33.6 kg)
	Available in Stainless Steel

MODEL G48EP	GIANT 48 OZ. ELECTRIC WITH PUMP
Capacity:	48 oz. All-Steel Kettle, 960 one-ounce servings per hour
Wattage:	6800 watts
Dimensions:	10-5/8"D x 10-1/2"W x 31-3/4"H - - - - 27 cm D x 26 cm W x 81 cm H
Net Weight:	74 lbs. (33.6 kg)
	Available in Stainless Steel

MODEL G60EP	GIANT 60 OZ. ELECTRIC WITH PUMP
Capacity:	60 oz. Stainless- Steel Kettle, 1200 one-ounce servings per hour.
Wattage:	6800 watts
Dimensions:	10-5/8"D x 10-1/2"W x 31-3/2" H - - - - 27 cm D x 26 cm W x 81 cm H
Net Weight:	74 lbs. (33.6 kg)

---

## V. PURPOSE OF MANUAL

This instruction manual is intended to familiarize owners with the servicing and safety procedures associated with your Cretors popcorn machine.

This manual should be kept available to maintenance personnel.

---

## VI. INSTALLATION INSTRUCTIONS

### A. Location

Choose a location for your Cretors popcorn machine that maximizes the ease of operation and maintenance procedures. Giant pedestal popcorn machines are designed to be installed on the customers counter or custom design cabinet. OEM option machines are supplied with components that permit them to be installed into a user's cabinet and control the conditioner, lights and exhaust in the cabinet (see details below). Be sure to check your local building and fire codes for location restrictions.

### B. Power Supply

1. Check the nameplate to determine the required power supply.



Connect your popcorn popper only to the correct power source. Failure to do so may result in personal injury or death and may damage your popper.

2. C. Cretors and Company recommends dedicated circuits for the Giant model popcorn machine. The Giant model poppers require a dedicated circuit to avoid a voltage drop in the supply wiring. Check your local electrical codes regarding fuse or circuit breaker requirements.



Make certain your popcorn machine is properly grounded. Failure to do so may result in damage to your equipment or present a shock hazard.

### C. Connecting Machine to Power Supply

1. Make certain that power supply circuit breakers are in the off position.
2. Locate the pedestal and bolt it down securely using the four bolt holes provided in the base of the pedestal.
3. Power should be connected through one of the four large holes in the base of the pedestal.
4. Giant is supplied with a power cord. Be sure to follow the wiring diagram that was provided with this machine.



## D. OEM Option Pedestals

1. OEM OPTION machines are designed to supply power to the components normally associated with the popcorn machine. The primary features are a power cord with plug and a flexible armored cable to be connected to the user's conditioner assembly (15 amps). In addition, a terminal strip inside the pedestal provides a connection point to a switch (15 amps) that will control a user's exhaust fan.
2. EXHAUST FAN CONTROL machines may be equipped with a time delay fan control. This control provides a timer controlled switch that will turn on a customer's exhaust fan when the kettle heat is turned on. When the heat is turned off the fan will continue to run for the time set on the timer in the pedestal. This circuit only provides a switch, it does not supply any power.



All electrical connections outside the pedestal must be done in accordance with appropriate electrical codes and requirements.

## E. Pump Installation & Timer Adjustment for Salt/Sugar Machines

Refer to the Service Manual included with the pump to be installed in the machine. When the Giant is equipped with the salt/sugar option, also see below for additional information.

1. For the Salt/Sugar machine the pump timers are located in the machine not in the pump. One timer is marked "Salt", the other "Sugar". The timers are located in the pedestal.
2. To adjust the pump time, use the following procedure:
  - a. There are two adjustments on the timer. The small adjustment knob sets the maximum time the timer can run. Creators will normally set this adjustment for 10s.

10s = 0-10 seconds

1m = 0-1 minute

10m = 0-10 minutes

- b. The larger adjustment knob sets the actual run time (percentage of time allowed by the small adjustment knob). Example: If the maximum setting is set for 10s and the large knob is set at .9, the timer will run for 9 seconds. Adjust to taste for both timers.

## VII. SERVICE INSTRUCTIONS



In the case of improper operation, only a qualified person should perform the following diagnostic checks, and, if necessary, corresponding adjustments and repairs. Many of the following procedures present an electrical shock hazard and can cause serious injury or death.



Perform work only on de-energized circuits. Failure to do so may lead to electrical shock resulting in personal injury or death.

### A. Parts

When ordering parts, refer to the parts diagram and/or wiring diagram included in this manual. Always supply the serial number, model number, and voltage of your popcorn machine.

### B. Kettle Temperature Control

#### 1. TEMPERATURE CONTROL OPERATION

- a. The temperature control is installed as a safety device to prevent overheating of the kettle if the machine should be left unattended momentarily while in operation. The kettle indicator light indicates the operation of the temperature control. If equipped, the indicator light is located on the switch plate. The indicator light will turn off 10-20 seconds before the corn finishes popping and the kettle is dumped. If the indicator light turns off 30 seconds or more before the corn finishes popping, the temperature control is set too low and in need of adjustment. If the indicator light remains on after corn has finished popping the digital temperature control is set too high.
- b. Salt/Sugar Option: The indicator lights on the switchplate will reflect whether the Salt/Sugar switch is in the sugar mode or salt mode. When the Salt/Sugar switch is in the sugar mode, the digital temperature control alone controls the heat. When the switch is on the salt side the digital temperature control works the same way with one exception. When the digital temperature control opens, it activates a timer which allows the heat to stay on for extra time allowing the salted corn to pop.
- c. Digital Control does not have a thermostat but a thermocouple on the bottom of the pan.
- d. Creators "CE" marked machines have been supplied with high limits for years to comply with the European Directives but these high limits are not resetting. Once they trip, they need to be replaced. This has not changed.

Beginning in May of 2006, Cretors and Company has started implementing auto-resetting high limits into kettles and repair kettles as well. Again, the end customer/user will not see any difference in the operation of their machine but there is now an added level of safety so that the kettle temperature will not be able to exceed a safe level, even if the normal operating thermostat or temperature controller is adjusted to an unsafe level. This high limit is preset and is NOT to be adjusted for any reason. New wiring diagrams will be sent out with the new kettle assemblies for reference.

## 2. DIGITAL TEMPERATURE CONTROL ADJUSTMENT



**CAUTION:** If the corn has dried out, it may not finish popping at normal temperatures, and the light may appear to go out early. DO NOT ADJUST KETTLE TEMPERAUTRE BASED ON POOR QUALITY CORN.



If set too high (over 500°F 260°C), the digital temperature control can cause a serious fire hazard.



**CAUTION:** If the machine is equipped with the Salt/Sugar option, the temperature control should only be adjusted when the switch is in the sugar mode. When in salt mode, refer to “Salt timer adjustment” section.

- a. Press the “set” button.
- b. Use the up or down arrow buttons to adjust the temperature up or down.
- c. Press the “set” button again. (Note that for safety, this range is limited)
- d. The display will show the temperature go up or down.
- e. You should only raise or lower the temperature 5-10 °F at a time.
- f. Set temperature so that the power to heat elements is cut off at the correct temperature.

<u>KETTLE</u>	<u>SALTED CORN</u>	<u>SUGAR CORN</u>
20-60 OZ.	400-410° F. (204-210° C)	375-385° F. (190-193° C)

## 3. CHECKING TEMPERATURE CONTROL

There are two ways of checking that the temperature control is set correctly.

- a. Place the pyrometer over the thermocouple position and turn the kettle heat on. Watch to see that the kettle heat shuts off at the correct

temperature. Make adjustments as needed.

- b. The temperature control may be adjusted by observing the operation of the indicator light as described in the "Temperature Control Operation" section. Adjust the temperature control so that the kettle heat is turned off 10 to 20 seconds before the corn finishes popping and the kettle is dumped.



Do not adjust the temperature so high that the pan smokes at the end of the popping cycle. If set too high (over 500°F or 260°C), the kettle can become a serious fire hazard.

- c. Observe two or three cycles of correct operation to be certain everything is working correctly. Your final setting should allow the indicator light to cycle off 10 to 20 seconds prior to dumping the kettle.

#### 4. SALT TIMER ADJUSTMENT (For machines supplied with Salt/Sugar Option only)

When the Salt/Sugar switch is in the sugar mode, the thermostat alone controls the heat. When the switch is in the salt mode, the temperature control works the same way with the exception that when the temperature control opens, it activates a timer, which allows the heat to stay on for an extended period of time allowing the salted corn to pop. The salt timer is located in the pedestal of all Giants marked "Salt Timer". In salt mode:

- a. If the indicator light turns off 30 seconds or more before the corn finishes popping, the timer is set too low and is in need of adjustment.
- b. There are two adjustments on the timer. The small adjustment knob sets the maximum time the timer can run. Cretors will normally set this adjustment for 1m.

10s = 0-10 seconds

1m = 0-1 minute

10m = 0-10 minutes

- c. The larger adjustment knob sets the actual run time (percentage of time allowed by the small adjustment knob). Example: If the maximum setting is set for 1m and the large knob is set at .5, the timer will run for 30 seconds. In this case, the heat will stay on 30 seconds after the temperature control opens.

#### 5. SALT/SUGAR WITH ONE POP ADJUSTMENT

- a. If the Salt/Sugar switch is in the sugar position, use the "Digital Temperature Control Adjustment" section.
- b. If the Salt/Sugar switch is in the salt position, the temperature is adjusted on the One Pop Timer/Relay.

- c. On the Relay there are dip switches very similar to the timer in our 7700-7900 pumps.
- d. From the factory the dip switches 7 and 9 will be on. To turn the dip switches ON the dip switch needs to be pressed down to the number side opposite of the open side.

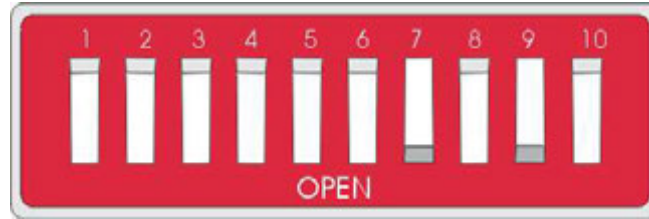

Switch #6 = 5 seconds  
 #7 = 10 seconds  
 #8 = 20 seconds  
 #9 = 40 seconds

Example: If you turn #7 and #9 on, the time delay will be 50 seconds.

### C. Kettle Removal

To remove the kettle assembly, perform the following operations:

1. Unplug the popcorn machine from the power supply. Make sure the kettle is not hot.
2. Remove the cover on the terminal box between the pan support legs.
3. Disconnect the three power leads, observing the color of the wires. Correct color code is: Left to right, BLACK, RED, WHITE. (For 400V units BLUE, BROWN, WHITE on front terminal left to right, Black on back terminal.)
4. Remove the two bolts on the side of the aluminum pan legs.



Using proper lifting techniques, when removing the kettle by lifting it straight up.

5. Turn the kettle upside down and remove the bolts that hold the dump handle and retainer and lift the retainer off the kettle.
6. When removing nuts and spacers from the threaded studs on the bottom of the pan, do not wipe off the silver lubricant. Without this lubricant (NEVER SEEZ) the nuts may freeze on the studs and cause the studs to break when the nuts are turned in an attempt to remove them.

## D. Kettle Installation

1. When re-assembling the kettle, be sure all nuts and bolts are tight. Check to make sure that all electrical connections are secure. A loose connection can heat up and burn off the wires.
2. Set the kettle back in place and replace the two bolts in the pan legs.
3. Locate the kettle so that the clutch dog lines up with the motor drive head, and tighten the two front bolts that hold the pan leg plate, then tip the kettle and tighten the other two bolts.
4. Connect the three power leads, observing the color of the wires. Again, correct color code is left to right, BLACK, RED, WHITE. (For 400V units BLUE, BROWN, WHITE on front terminal left to right, Black on back terminal.)
5. Replace the terminal box cover.
6. Turn on the agitator motor and dump the kettle. If the drive shaft does not engage and dis-engages freely, readjust the kettle.

## E. Kettle Spring Adjustment

The purpose of the kettle counter balance springs is to reduce the force required to dump the kettle. The spring collars are held in place by set screws that fit into holes drilled on the bottom of the cross shaft. The spring collars have five holes that the spring fits into. By turning the collar around, there are five different adjustment positions for spring tension adjustment.

When correctly adjusted the springs will neutralize the weight of the kettle. To set the springs raise the kettle to a point where it is balanced. The long leg of the 1902 spring should be just beginning to touch the bar on the bottom edge of the hinge casting and the 1903 spring will begin to move away from the bar. If the springs press against the bar too soon the kettle will seem lighter but the springs are fighting each other. This condition will shorten the life of the springs.

An important part of this assembly are the two washers between the 1902 spring and the plate welded to the cross shaft. They act as both bearings and spacers; without them the spring may have a short life.

## VIII. TROUBLESHOOTING

PROBLEM	POSSIBLE CAUSE	ACTION
Popping is slow.	Incorrect amount of corn and oil is used.	Refer to the chart located in the Operations Manual.
	Kettle indicator light goes out more than 30 seconds before the corn finishes popping.	Temperature is set too low. (Refer to "Digital Temperature Control Adjustment"). If machine is equipped with salt/sugar option and popping in salt mode, timer may be set low. (Refer to the "Salt Time Adjustment" or the "Salt/Sugar One Pop Adjustment" sections.
	Voltage may be low.	Check the voltage at the circuit breaker with the kettle heat on. Extension cords or inadequate wiring will provide full voltage, if no load is applied. Once the kettle heat and auxiliaries are turned on, the voltage may drop 5 to 10 volts.
Indicator light stays on. Digital Control never reaches temp.	One of the elements in a multi-element pan may have failed.	Use an ammeter to diagnose.
		Check the amperage draw of the heating elements, by using a clamp-on ammeter. 1. Remove the front cover by removing the screws that hold the front cover to the pedestal. 2. Turn on the kettle heat. 3. If machine has one-pop option shut off the oil switch and press the one-pop button. 4. Place the ammeter around the lead to the popper kettle as listed. The following current draws are normal. 120/208-240V and 100/200V machines black or red 230V machines-blue or brown 400V machines-black or brown.



**CAUTION:** If the corn has dried out, it may not finish popping at normal temperatures, and the light may appear to go out early. DO NOT ADJUST KETTLE TEMPERATURE BASED ON POOR QUALITY CORN.



**CAUTION:** Do not adjust the temperature so high that the pan smokes at the end of the popping cycle. If set too high (over 500°F or 260°C), the kettle can become a serious fire hazard.

<u>KETTLE SIZE</u>	<u>AMPS @ 200V</u>	<u>AMPS @ 208V</u>	<u>AMPS @ 230V</u>	<u>AMPS @ 240V</u>
20 oz.	12.5	13.0	10.8	11.2
32 oz.	19.6	20.4	17.0	17.7
48/60 oz.	26.8	28.1	23.4	24.4

380V – Place the ammeter around the black or brown lead to the popper kettle

<u>KETTLE SIZE</u>	<u>AMPS @ 380V Brown</u>	<u>Black</u>
32 oz.	8	9
48/60 oz.	11	13.2

<b>PROBLEM</b>	<b>POSSIBLE CAUSE</b>	<b>ACTION</b>
A low reading may indicate a problem in the kettle. One or more of the heat elements may not be functioning properly. If the element is not functioning, the possible causes are: 1. The element has burned out. 2. A lead wire has burned off one of the element terminals due to a loose connection.		In either case the kettle must be removed and the problem identified. 1. Remove kettle. (See section Kettle Removal for instructions.) 2. Check for short circuits inside the kettle. 3. If wires must be replaced, be sure to use nickel wire supplied by Cretors Conventional copper or “stove wire will have limited life. 4. Make a visual check for broken, loose, burned or heat damaged wires. If there are no obvious broken or loose wires shorting out on the kettle, the elements must be checked. 5. Perform a continuity test on the elements. It is possible that one of the elements has burned through the insulation and the casing is shorting out directly to the kettle bottom.





Replace failed heat elements with identical units available from your local dealer or from Cretors. Reassemble and reinstall kettle assembly onto the machine.

<b>32 oz. – 208V elements</b>	16336-4-D	750 Watt – 57.7 $\Omega$
	16336-3-D	1500 Watt – 28.8 $\Omega$
	16336-1-D	<u>2000 Watt – 21.6 <math>\Omega</math></u>
		4250 Watt - 10.2 $\Omega$ (total)
<b>32 oz. – 240V elements</b>	16336-4-C	750 Watt – 76.8 $\Omega$
	16336-3-C	1500 Watt – 38.4 $\Omega$
	16336-1-C	<u>2000 Watt – 28.8 <math>\Omega</math></u>
		4250 Watt - 13.6 $\Omega$ (total)
<b>48 oz &amp; 60 oz.. – 208V elements</b>	16336-4-D	750 Watt – 57.7 $\Omega$
	16336-2-D	3050 Watt – 14.2 $\Omega$
	16336-1-D	2000 Watt – 21.6 $\Omega$
		5800 Watt - 7.5 $\Omega$ (total)
<b>48 oz. &amp; 60 oz. – 240V elements</b>	16336-4-C	750 Watt – 76.8 $\Omega$
	16336-2-C	3050 Watt – 18.9 $\Omega$
	16336-1-D	2000 Watt – 28.8 $\Omega$
		5800 Watt - 9.8 $\Omega$ (total)

<b>PROBLEM</b>	<b>POSSIBLE CAUSE</b>	<b>ACTION</b>
Kettle will not heat.	The motor, light or any of the other components do not work.	Check power supply: 1. Is it plugged in? 2. Is the receptacle live? 3. Is the machine plugged into the proper voltage? (Measure with voltmeter and compare to specification on nameplate of machine.)
	Problem is in the machine.	Check the relay/contactator. The Giant temperature control uses a relay/contactator to control the power to the popper pan heat elements. To check the relay/contactator, perform the following operations: 1. To gain access to the relay/contactator, remove the front switchplate by removing the six screws on the sides of the switchplate. 2. Using a voltmeter, check the power to the relay coil, that are the small terminals in the center. 3. With the popper switch on, at room temperature, the temperature control should be calling for heat and providing power to the relay/contactator. If the coil reading is not 120 volts. (230 volts on 230V and 400V, 50Hz machines) the problem is in the temperature control. 4. If the coil reading is 120 volts, (230 volts on 230V and 400V machines) check the voltage between the output terminal with wire #1 and the output terminal with wire #3 from the kettle support. If this does not have a reading of 208 or 240 volts, the relay/contactator is not functioning and needs to be replaced.
	If machine has the one-pop option.	Use the same procedure as above. Then check the one-pop circuit. 1. With the power OFF. Check the one-pop switch for continuity by pressing and holding it down. Remove wires (mark wires for proper re-installation) from switch and press and hold. Using a multimeter, check for continuity from top to bottom of switch. If no continuity, replace switch. 2. Check the input (com) and output (no) on timer/relay.
Digital Temperature Control display shows EO	Thermocouple has bad connections.	Check all connections.
	Thermocouple is bad. Should read 3-5 ohms if good.	Replace thermocouple.

<b>PROBLEM</b>	<b>POSSIBLE CAUSE</b>	<b>ACTION</b>
Corn Burns	Agitator is not working.	Check to be certain the stirrer blade is on the bottom of the pan and is stirring the corn.
	Check motor connections.	Loose wire.
	The motor is bad.	Replace.
	The correct amount of corn and oil were not used.	See Operations Manual for correct amounts.
	Temperature is set too high.	Adjust temperature.
Kettle leaks oil at agitator.	If the kettle is not cleaned on a regular basis the popping oil will build up and turn to carbon on the inside of the blade center. When this happens the clearance between the blade center and the pan center is reduced from 1/8" (3mm). As this clearance is reduced, the oil will "wick" up the narrow space and run down the rotating shaft and it will appear that the kettle is leaking for 20 oz. kettles.	When reassembling, lightly coat the clutch dog shaft with moly grease or a comparable high temperature lubricant.
Pump will not heat.	Pump switch is on.	Check pump switch. Remove wires from switch (mark wires for proper re-installation.) Using a multimeter, check for continuity from top to bottom of switch. If no continuity, replace switch.

If you have any questions, contact your local distributor and if there are any additional questions, feel free to contact the Customer Service Department at C. Cretors and Company.

Additional copies of this manual can be obtained from C. Cretors and Company at the address listed below. Please provide model and serial number when requesting additional copies of this manual. There will be a nominal charge for additional copies.

Cretors guarantees this machine to be free of defects in parts, materials and workmanship for two years. Please take this time to fill out the factory registration card and return it to the factory to activate your warranty. If you have any questions concerning the Cretors' warranty, please contact your local distributor or the Customer Service Department at C. Cretors and Company.



We invented the popcorn machine  
**THEN JUST KEPT GOING!**

C. CRETORS AND COMPANY

176 MITTEL DRIVE

WOOD DALE, IL 60191

PHONE (773) 588-1690, (800) 228-1885, FAX (847) 616-6970

WEB SITE: <http://www.cretors.com> Email: [postmaster@cretors.com](mailto:postmaster@cretors.com)



176 MITTEL DRIVE  
WOOD DALE, IL 60191

PHONE: (847) 616-6900, (800) 228-1885 FAX: 847-616-6970  
WEB SITE: <http://www.cretors.com> Email: [postmaster@cretors.com](mailto:postmaster@cretors.com)

# C. CRETORS AND COMPANY SINGLE STAINLESS STEEL 70-INCH KNOCKDOWN TABLE Assembly Instructions after 10/18/11



The following instructions are broken down into three sections. The first details the assembly of the legs and popper shelf of the unit, the second details the assembly of the clean out drawers and corn drawer, and the last details the assembly of the bag filler on the front of the table.

## I. LEGS AND SHELF

The following instructions detail the assembly of the legs and shelf on the single-shelf 70-inch knockdown table.

This assembly requires the following parts:

Number	Part	Description
1	13579	KNOCKDOWN TABLE/RECEIVING TRAY
4	13581	KNOCKDOWN TABLE LEG
1	1666-SS	POPPER SHELF
6	14440	1/2-13 x 2 1/4 BOLT
4	10136	1/2-13 HEX NUTS
2	14266	SS 1/2-13 CAP NUT

2	10134	1/2 FLAT WASHER
6	10135	1/2 SPLIT WASHER
4	12750	1/4-20 x 2 BOLT
4	7639	1/4-20 CAP NUT
4	5743	1/4 SPLIT WASHER
4	5742	1/4 FLAT WASHER
2	12883	CASTER, SWIVEL W/ BRAKES
2	12882	CASTER, SWIVEL W/O BRAKES

Begin by making sure all parts are available.

Ready the Receiving Tray on a Table:

To do the following work, you must place the knockdown receiving tray so that it straddles another table perpendicularly. This will allow you to attach the legs as they hang below the tray. Be sure the tray is stable, crossing the table. Use a LEG to judge height. Leave at least six inches between leg bottom and floor.

Attach the Casters to the Legs:

Insert one of the CASTERS into one of the table LEGS in the end opposite of the holes. The black sleeve should be placed into each LEG. Turn the bolt at the base of the casters to expand the black sleeve in the LEG. This will hold the CASTER in the LEG. Repeat for the other three legs.



Attach Legs to the Tray:

Begin by laying out the four LEGS with the CASTERS so that the two CASTERS with brakes are on the same side as the cut out for the bag filler. Insert the tops of the LEGS (the leg end drilled with the holes) into the four corners of the RECEIVING TRAY. Feed the four 1/4-20 x 2 1/4 BOLTS from the tray side through the legs. Place the 1/4

FLAT WASHERS on bolt, then the 1/4 SPLIT WASHERS, then the CAP NUTS. For now, just hand-tighten the four BOLTS.

Attach the Lower Screws on the Side without the Shelf:

Determine if you would like the shelf on the right side or left side of the bag filler. Install the lower bolts on the non-shelf side legs. Use two 1/2-13 x 2 1/4 BOLTS, two 1/2 SPLIT WASHERS, and two SS 1/2-13 CAP NUTS. Insert the bolts from the inside of the tray, and secure them on the outside of the leg, using the CAP NUTS and SPLIT WASHERS. Tighten.

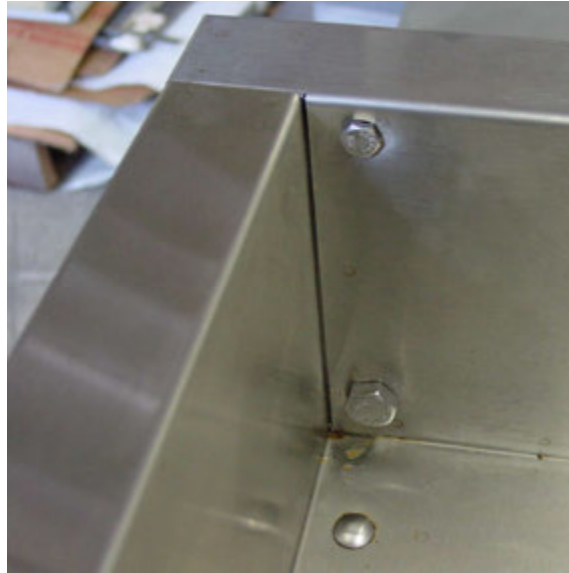

Attach the Shelf:

1. Hold the POPPER SHELF in position on the other side of the TRAY.



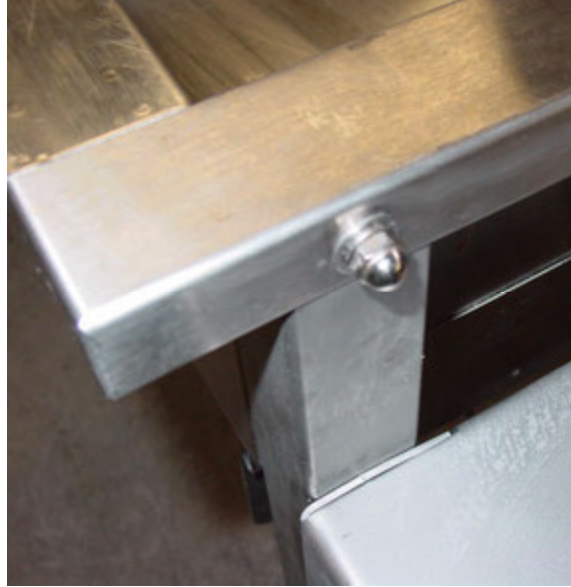

2. Using two 1/2-13 x 2 1/4 BOLTS, two 1/2-13 HEX NUTS, and two 1/2 SPLIT WASHERS, attach the top bolts to hold the SHELF in position, using the topmost holes beneath the SHELF. Insert the BOLTS from the inside of the TRAY, and secure the BOLTS with the SPLIT WASHERS and HEX NUTS beneath the SHELF.
3. Using two 1/2-13 x 2 1/4 BOLTS, two 1/2 FLAT WASHERS, two 1/2 SPLIT WASHERS, and two 1/2-13 HEX NUTS, attach the lower bolts beneath the POPPER SHELF. Insert the BOLTS as shown in following picture, from the non-SHELF side of the legs. Place the FLAT WASHERS then the SPLIT WASHERS on the bolts on the SHELF-side of the legs, then secure with HEX NUTS.
4. Tighten all nuts and bolts.



## II. CLEAN OUT DRAWERS AND CORN DRAWER

The following instructions detail the assembly of the clean out drawers and corn drawer assembly on the single-shelf 70-inch knockdown table.

This assembly requires the following parts:

Number	Part	Description
2	1360	CLEAN OUT DRAWER/WASTE DRAWER
1	5857-RA	CORN DRAWER-ROLLER ASSEMBLY
1	3817	CORN DRAWER COVER
2	14436-L	CORN DRAWER SUPPORT-LEFT
2	14436-R	CORN DRAWER SUPPORT-RIGHT
8	12749	1/4-20 x 1/2 SS CARRIAGE BOLT
8	12343	1/4-20 SERRATED HEX FLANGE NUT

Install the Four Corn Drawer Supports:



Position the CORN DRAWER SUPPORTS so that the CLEAN OUT DRAWERS may be slid between them, right beneath the table as shown. Screw the four CORN DRAWER SUPPORTS onto the table, each SUPPORT requires two 1/4-20 x 1/2 CARRIAGE BOLTS and two 1/4-20 SERRATED HEX FLANGE NUTS. Note: There are no washers needed. Insert the BOLTS from the top of the table, and tighten the HEX FLANGE NUTS on the SUPPORT sides.

Install the Corn Drawer and the Clean Out Drawers:

Insert the CORN DRAWER into the roller guides by placing the two rear rollers into the channel, then pushing back until the two front rollers drop into the roller guides. Next, place the CORN DRAWER COVER on the CORN DRAWER. Lastly, insert the two CLEAN OUT DRAWERS into the DRAWER SUPPORTS.



### III. BAG FILLER

The instructions follow for the assembly of the bag filler on the single-shelf 70-inch knockdown table.

This assembly requires the following parts:

Number	Part	Description
1	1493-1	BAG FILLER – TOP ATTACHMENT
1	1493-2	BAG FILLER – BOTTOM ATTACHMENT
1	1493-3	BAG FILLER – SLIDE
8	7650	1/4-20 x 3/8 BOLTS
8	7639	1/4-20 CAP NUT
8	7621	1/4 STAR LOCKWASHER
2	7626	10-24 x 3/4 SCREW
2	7796	10-24 CAP NUT
2	10098	3/8 SS SPACER
2	2554	FASTENER-LUDWIG
2	7790	#10 STAR LOCKWASHER

Begin by making sure all parts are available.

Assemble the Bag Filler:

1. Place the BAG FILLER – TOP upon the BAG FILLER – BOTTOM, so that the holes line up and the lips line up toward the front. Place the BAG FILLER – SLIDE into place as you do this. Secure the assembly with four 1/4-20 x 3/8 BOLTS, four 1/4 STAR LOCKWASHERS, and four 1/4-20 CAP NUTS. Be sure to feed the BOLTS through from the top, and place the LOCKWASHERS on the bottom side, near the CAP NUTS. Tighten.
2. Turning the bag filler on its side to expose the bottom, install the bag clips on either side below. Use two 10-24 x 3/4 SCREWS, two 3/8 SS SPACERS, two FASTENERS, two #10 STAR LOCKWASHERS, and two 10-24 CAP NUTS. Be sure to position the FASTENERS on the outside, with 3/8 SS SPACERS between SCREW and FASTENER. Be sure the Ludwig name is on the outside and right-side up. There will be tension between the clip and the bag filler wall. On the inside, place a #10 LOCKWASHER, and secure clips with 10-24 CAP NUTS. Tighten well.
3. Screw the bag filler to the table. Use four 1/4-20 x 3/8 BOLTS, four 1/4 STAR LOCKWASHERS, and four 1/4-20 CAP NUTS. Be sure to feed the bolts through from the outside to the inside of the table, and place the LOCKWASHERS on the inside wall of the table. Tighten.



# CRETORS AND COMPANY TWIN STAINLESS STEEL 70-INCH KNOCKDOWN TABLE Assembly Instruction Modifications

The twin-shelf knockdown table is constructed in the same fashion as the single-shelf model, with the following modifications:

## I. LEGS AND SHELF

Instead of installing the lower bolts on the non-shelf side of the tray, install the additional shelf. The following additional hardware will be included:

Number	Part	Description
1	1666-SS	POPPER SHELF
2	14440	1/2-13 x 2 1/4 BOLT
4	10136	1/2-13 HEX NUT
2	7781	1/2 FLAT WASHER
2	10135	1/2 SPLIT WASHER

The following hardware will NOT be included:

Number	Part	Description
2	14266	SS 1/2-13 CAP NUTS

Install the second shelf as you did the first on the opposite side of the table.



# CRETORS AND COMPANY STAINLESS STEEL 70-INCH KNOCKDOWN TABLE WITH COOLING FAN Assembly Instruction Modifications

The knockdown table with cooling fan is constructed in the same fashion as the single and twin-shelf models, with the following modifications:

## I. COOLING FAN

The following additional hardware will be included:

Number	Part	Description
1	13564	COOLING BOX ASSEMBLY
2	12985	1/4-20 x 5/8 BOLT
3	5743	1/4 SPLIT WASHER

Remove screen from end with cooling fan cutouts. As one person holds the cooling box assembly, align the mounting holes and insert bolts and washers. Tighten all bolts.



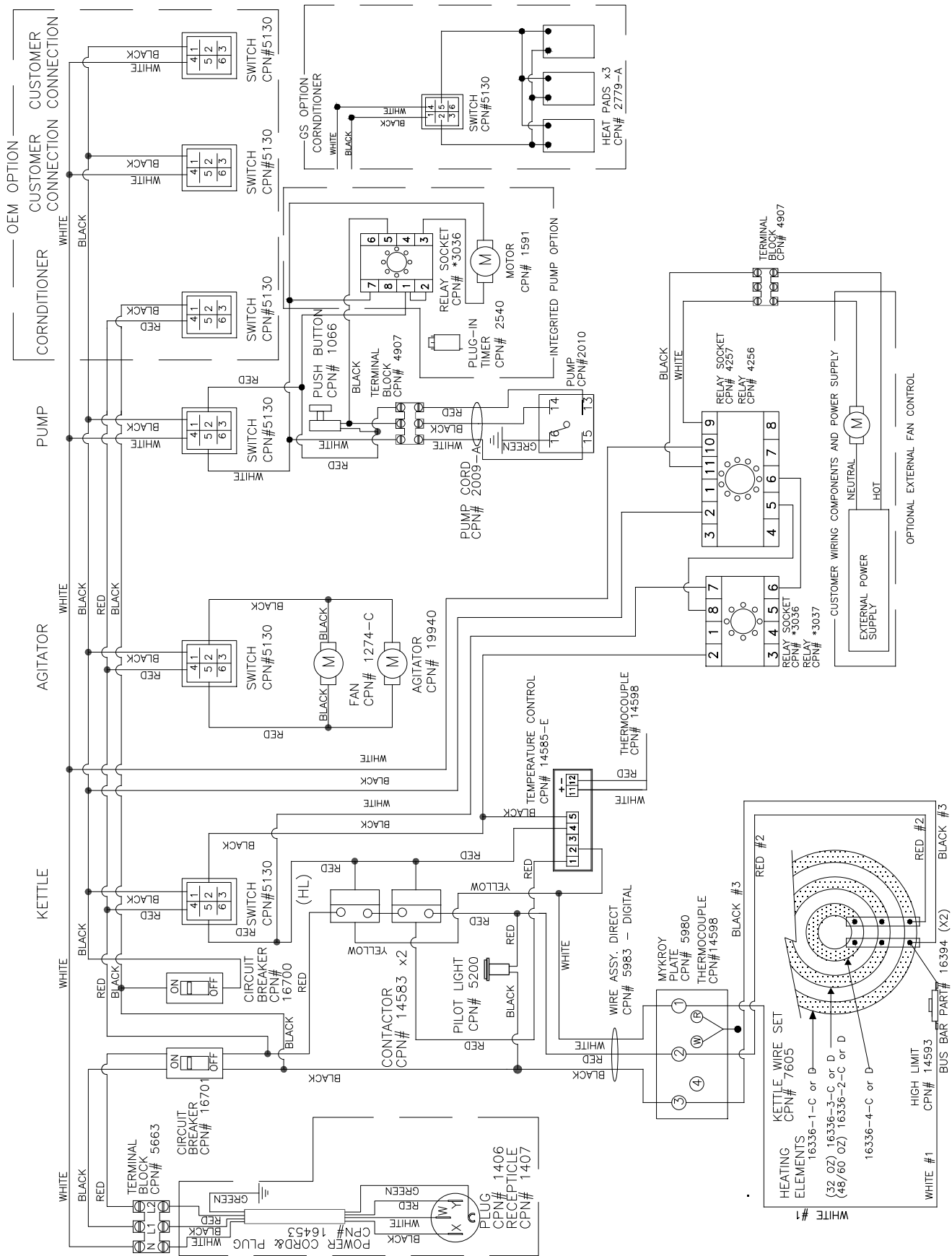

**EG(PR) 32/48/60 ONE PIECE KETTLE BREAKDOWN**  
**120/208; 120/240; 230V; 400V**

DOC: G2000049

G32/48/60-C/D/E/G-2.1-A  
 05/2010

UPSIDE-DOWN VIEW

BEG. SERIAL NUMBER: 10050604

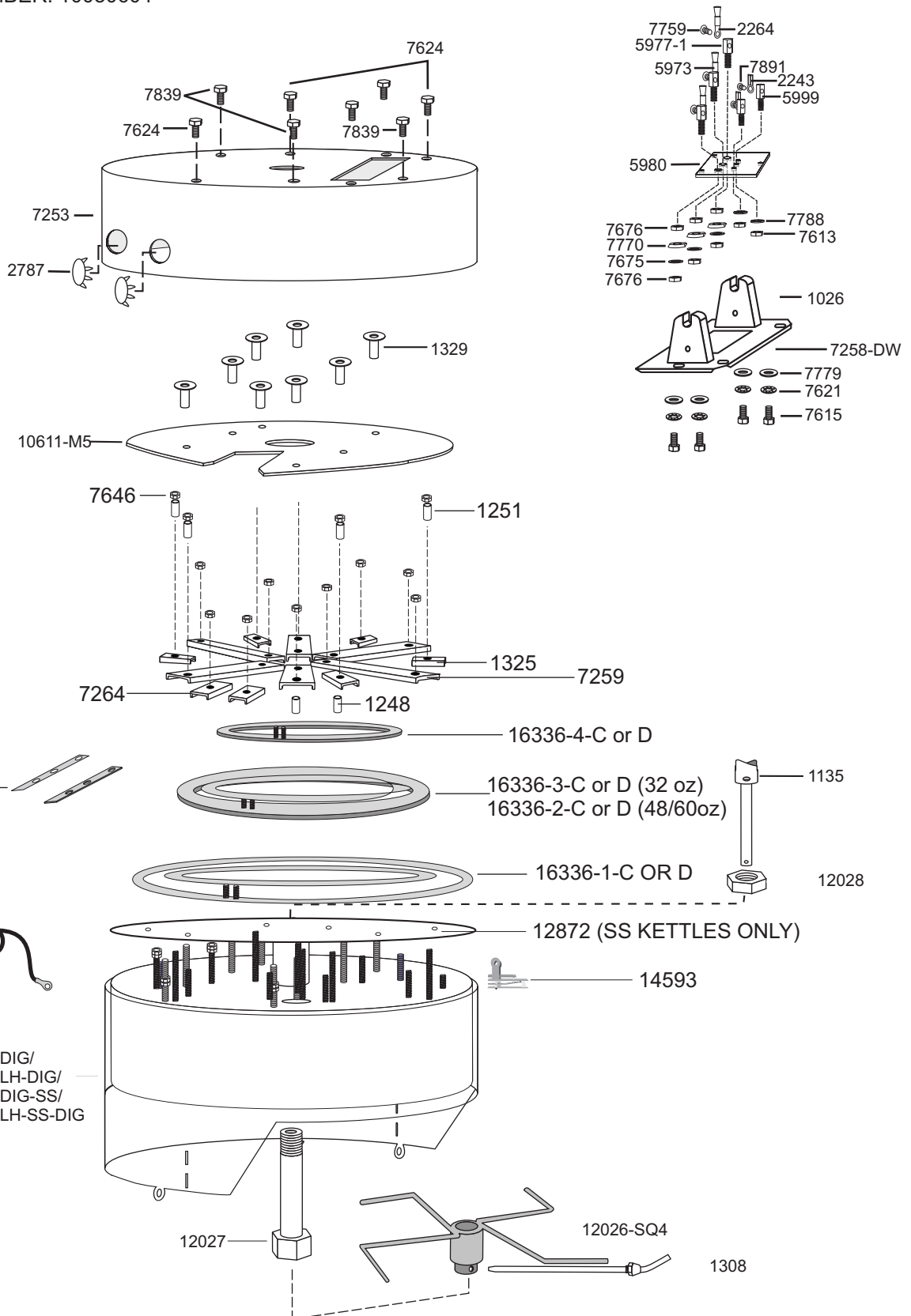

FOR CE MARKED MACHINES, 3918 WAS REPLACED WITH 14593 AND 14942 ON 400v MACHINES BEGINNING 07/08.



14942 (LOCATED IN CABINET)

16394 (400v kettles use 1 16394 and 1 16395 not shown)

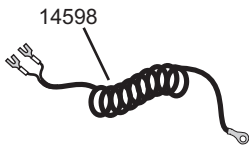

12267-DIG/  
 12267-LH-DIG/  
 12267-DIG-SS/  
 12267-LH-SS-DIG



**EG(PR) 32/48/60 ONE PIECE KETTLE BREAKDOWN**  
**120/208; 120/240; 230V; 400V**

DOC: G2000049

G32/48/60-C/D/E/G-2.1-A  
05/2010

UPSIDE-DOWN VIEW

BEG. SERIAL NUMBER: 10050604

1026	PAN LUG	12028	CENTER STUD LOCKNUT
1135	CLUTCH DOG AND SHAFT	12267-DIG	POPPER PAN-ONE PC. DROP-48 OZ -DIG
1251	5/8" SPACER	12267-LH-DIG	POPPER PAN 48 OZ.-LEFT HAND - DIG
1308	ANTI-PAK PIN	12267-SS-DIG	POPPER PAN - SS ONE PC. DROP- 48 OZ DIGITAL
1325	ELEMENT CLAMP 3-1/4"	12267-LH-SS-DIG	POPPER PAN - SS - 48oz - LEFT HAND DIGITAL
1329	RETAINER HEX SPACER	12872	DIFFUSER PLATE
2243	TERMINAL-WIRE	14593	HIGH LIMIT
2264	HIGH TEMP. TERMINAL	14598	THERMOCOUPLE-GIANT
2787	HOLE PLUG 1/2"	14942	HIGH LIMIT-LATCHING RELAY
5973	HEAT SHRINK	16336-1-C	ELEMENT 2000 WATT, 240 VOLT
5977-1	WIRE TERMINAL STUD	16336-1-D	ELEMENT 2000 WATT, 208 VOLT
5980	MYROY PLATE	16336-2-C	ELEMENT 3050 WATT, 240 VOLT (48/60 OZ)
5999	THERMOCOUPLE STUD	16336-2-D	ELEMENT 3050 WATT, 208 VOLT (48/60 OZ)
7253	RETAINER	16336-3-C	ELEMENT 1500 WATT, 240 VOLT(32OZ)
7258-DW	PAN LEG PLATE-G48/60E-DIRCT WIRE	16336-3-D	ELEMENT 1500 WATT, 208 VOLT(32OZ)
7259	ELEMENT CLAMP 5-1/4"	16336-4-C	ELEMENT 750 WATT, 240 VOLT
10611-M5	BAFFLE PLATE	16336-4-D	ELEMENT 750 WATT, 208 VOLT
7264	ELEMENT CLAMP 1-5/8"	16394	NICKEL STRAP-4.5"
7605	KETTLE WIRE SET	16395	KETTLE ELEMENT JUMPER - 400V
7613	6-32 X 5/16 X 7/64 HEX NUT	16400	ELEMENT SPACER
7615	1/4-20 X 3/4 HEX CAP SCREW		
7621	1/4" INTERNAL TOOTH LOCKWASHER		
7624	1/4-28 x 1/2 HEX CAP		
7646	1/4-28 HEX NUT		
7675	# 10 FLAT MONEL WASHER		
7676	10-32 MONEL NUT		
7759	10-32 SCREW		
7779	1/4" SAE FLAT WASHER		
7788	#6 STAR LOCKWASHER		
7797	4-36 x 1/8 SLOTTED BINDER HEAD		
7839	1/4-28 x 5/8 HEX HEAD		
7891	8-32 X 3/16 SS PAN HEAD SCREW		
10313	KETTLE WIRE SET (400V ONLY)		
10611-M5	BAFFLE PLATE		
12026-SQ4	STIRRER BLADE - 4 BLADE SQUARE		
12027	PAN CENTER 1 PC		

C. CRETORS AND COMPANY  
3243 N. CALIFORNIA AVENUE  
CHICAGO, IL 60618

PHONE: (773)588-1690, (800)228-1885, FAX: (773)588-2171

WEB SITE: <http://www.cretors.com> Email: [postmaster@cretors.com](mailto:postmaster@cretors.com)

**PR32,EG32,PR48,EG48,PR60,EG60**  
**ONEPIECEKETTLE&PEDESTAL PARTS**  
**120/208V,120/240V/60Hz**  
**ONE POP & SALT/SUGAR OPTION**  
 BEGINNING SERIAL: 1810000

DOC: G2000050 G1P32/48/60-C/D-2.0-B  
 10/2018

**KETTLE ASSEMBLIES**

- (All have -DIG suffix)  
 7251ZP-C-DIG  
 7251ZP-D  
 7251ZP-C-LH.  
 7251ZP-D-LH  
 7251ZP-C-SS  
 7251ZP-D-SS  
 7251ZP-C-LH-SS.  
 7251ZP-D-LH-SS  
 7594ZP-C  
 7594DWIP-D  
 7594ZP-C-LH.  
 7594ZP-D-LH  
 7594ZP-C-SS  
 7594ZP-D-SS  
 7594ZP-C-LH-SS.  
 7594ZP-D-LH-SS

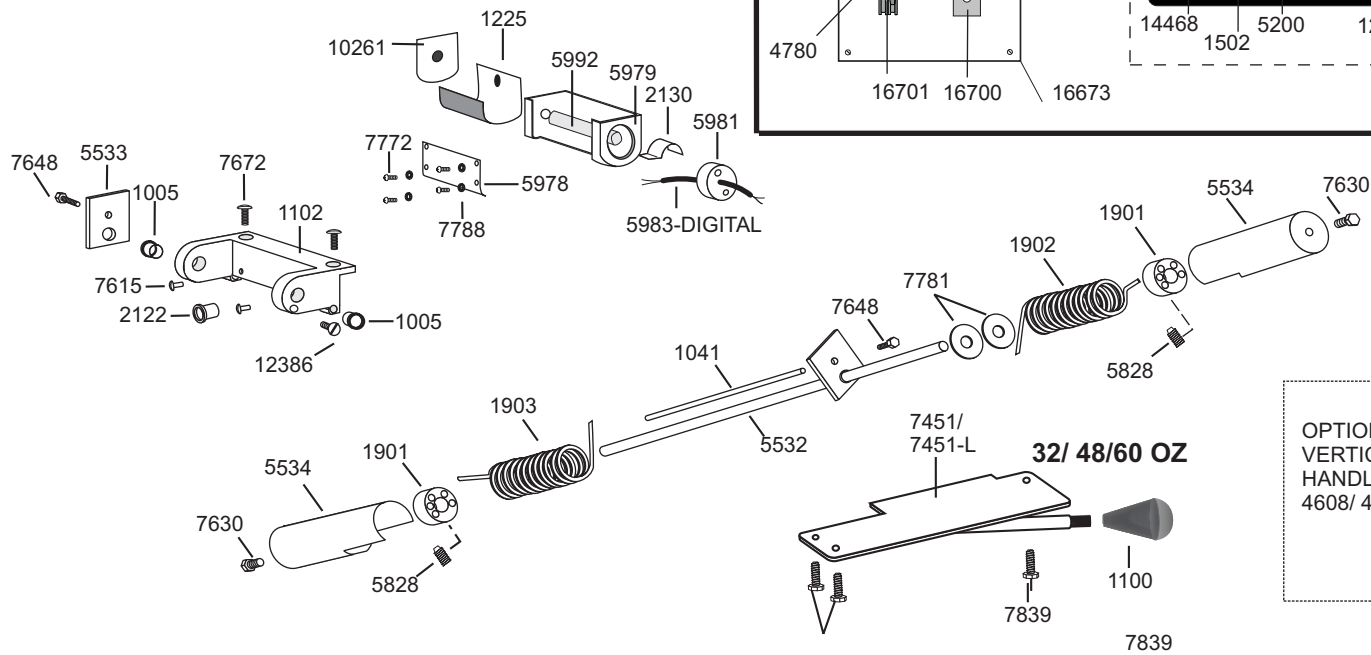
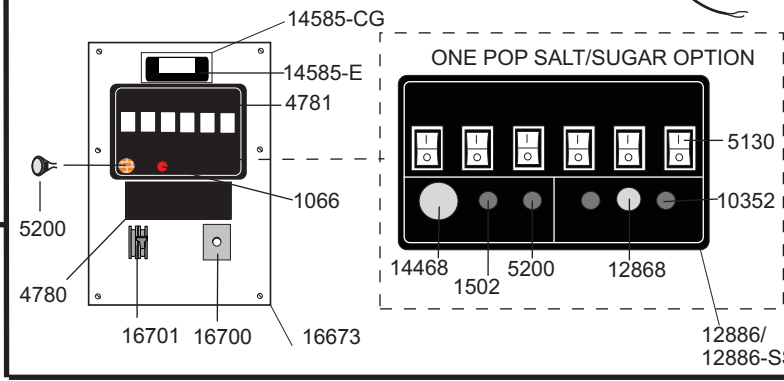
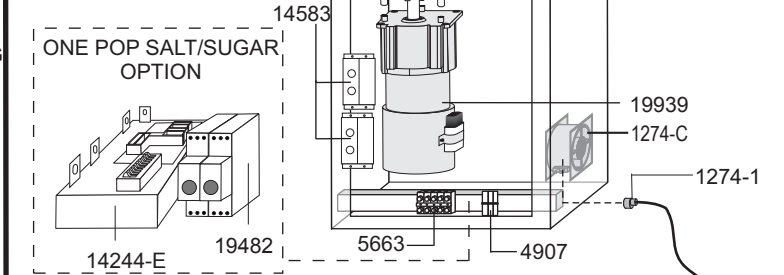
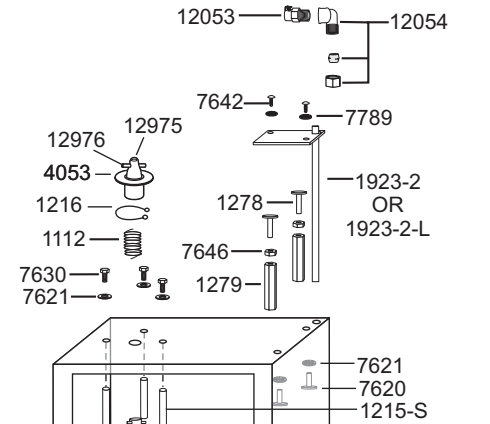
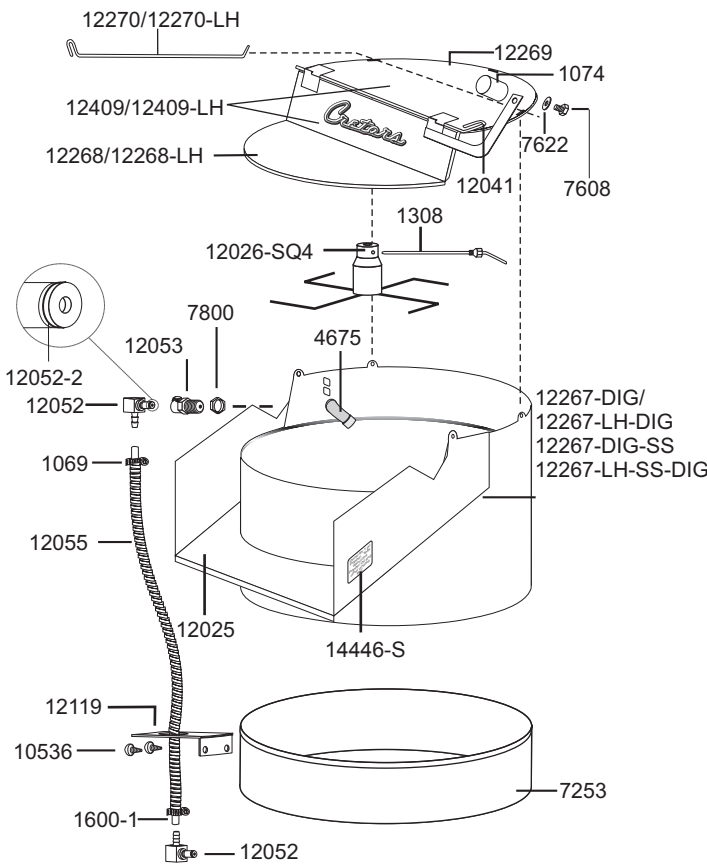

OPTIONAL  
 VERTICAL DUMP  
 HANDLE  
 4608/ 4608-L

**PR32, EG32, PR48, EG48, PR60, EG60**  
**ONE PIECE KETTLE & PEDESTAL PARTS**  
**120/208V, 120/240V/60Hz**  
**ONE POP & SALT/SUGAR OPTION**  
BEGINNING SERIAL: 10050000

DOC: G2000050 G1P32/48/60-C/D-2.0-B  
05/2010

1005	OILITE BEARING	7451-L	DUMP HANDLE - G32/48/60E LEFT HAND
1026	PAN LUG	7608	3/8-24 x 3/8 HEX HEAD
1041	PAN DUMP SPRING ROD	7615	1/4-20 X 3/4 HEX CAP SCREW
1066	SWITCH - PUSH BUTTON	7620	1/4-28 x 3/8 HEX HEAD
1069	CLAMP HOSE	7621	1/4" INTERNAL TOOTH LOCKWASHER
1074	COUNTERWEIGHT	7622	3/8 WASHER
1100	DUMP HANDLE KNOB	7624	1/4-28 x 1/2 HEX CAP
1102	KETTLE SUPPORT BRACKET	7630	1/4-20 x 1/2 HEX BOLT
1112	STIRRER SHAFT SPRING	7642	8-32 x 3/8 SS TRUSS HEAD
1140	PAN CENTER	7646	1/4-28 HEX NUT
1215-S	MOTOR MOUNT STUD SET (3)	7648	5/16-18 x 3/4 CAP SCREW
1216	DRIVE HEAD RETAINING RING	7650	1/4-20 x 3/8 HEX HEAD
1225	FISH PAPER	7659	10-24 x 3/4 FILL HEAD W/SPACER TUBE
19939	MOTOR	7672	1/4-20 x 3/4 OVAL HEAD SCREW
1278	KETTLE LEVEL ADJ. SCREW	7772	6-32 x1/4 BINDING HEAD
1279	KETTLE ADJUSTING SPACER	7779	1/4" SAE FLAT WASHER
1308	ANTI-PAK PIN	7781	1/2 " FLAT WASHER
1319	PAN CENTER WASHER	7788	#6 LOCKWASHER
1502	INDICATOR LIGHT - GREEN	7789	# 8 STAR WASHER
1600-1	TUBING-SILICONE PER FOOT	7800	1/4" NPT HEX THIN NUT
1901	SPRING COLLAR	7839	1/4 -28 x 5/8 HEX HEAD
1902	DUMP SPRING - 13 COIL	7898	10-24 x 1/2 SS WELD SCREW
1903	DUMP SPRING - 10 COIL	7839	1/4-28 x 5/8 HEX HEAD
1923-2	DISCHARGE TUBE BOTTOM- 32 OZ	10261	FISHPAPER WASHER DIRECT WIRE
1923-2-L	DISCHARGE TUBE BOTTOM-LONG	10352	INDICATOR LIGHT W/TABS
2122	BUSHING HEYCO	10536	6-32 x 3/8 SHEET METAL SCREWS
2130	PIPE CLAMP	12025	KETTLE APRON - 1 PC
3913-1	3/8 SS FLEXIBLE CONDUIT	12026-SQ4	STIRRER BLADE ASSY
14446-S	DECAL - CORN	1204	HINGE PIN - 1 PC
4053	MOTOR DRIVE HEAD W/SHIELD	12052	ELBOW - DIRECT OIL
4261	CIRCUIT BREAKER - 120V/15A	12052-2	"O" RING
4675	1/4" SS ELBOW	12053	COUPLING DIRECT OIL
4780	DECAL - INSTRUCTIONS - 20/32/48	12054	1/4" NPT TO 3/8" TUBE RIGHT ANGLE
4781	DECAL - SWITCH	12055	TUBE COVER- 3/8" x 24" SS FLUID CONDUIT
16673	SWITCHPLATE - ROCKER - DIGITAL	12119	OIL TUBE BRACKET
4907	TERMINAL BLOCK 40 AMP	19482	TIMER- 120V/230V DUAL - OFF DELAY
5130	SWITCH - LIGHTED	12268	KETTLE COVER - FRONT
5200	INDICATOR LIGHT	12269	KETTLE COVER - REAR
16701	CIRCUIT BREAKER - 50 AMP	12270	KETTLE COVER PIN
5532	CROSS SHAFT	12409	KETTLE COVER ASSY 1 PC/2 PIN
5533	CROSS SHAFT LUG	12868	TOGGLE SWITCH-3PDT-ON/OFF
5534	SPRING COVER	16673	SWITCHPLATE - ONE POP - DIGITAL
5663	TERMINAL BLOCK	12886	DECAL - ONE POP (SS = SALT SUGAR)
5828	5/16-24 x 1/2 HALF DOG PT. SET SC	12975	1/4-28 X 3/16 SET SCREW
5977	WIRE TERMINAL STUD	12976	DRIVE PIN-MOTOR DRIVE HEAD
5979	TERMINAL HOUSING - DIRECT WIRE	14468	SWITCH-DOUBLE POLE-PUSH BUTTON
5978	TERMINAL COVER PLATE	14583	RELAY-120V.-SINGLE POLE
5980	MYKROY PLATE	14585-E	DIGITAL CONTROLLER - 120V
5981	BAKELITE WASHER	14585-CG	DIGITAL CONTROLLER GUARD
5983-DIGITAL	WIRE ASSY-DW (C,D,E)		
5992	INSULATOR TUBE		
7253	RETAINER - G32/48/60E		
7451	DUMP HANDLE - G32/48/60E		

**C. CRETORS AND COMPANY**  
3243 N. CALIFORNIA AVENUE  
CHICAGO, IL 60618  
PHONE: (773)588-1690, (800)228-1885, FAX: (773)588-2171  
WEB SITE: <http://www.cretors.com> Email: [postmaster@cretors.com](mailto:postmaster@cretors.com)