

# GAS GIANT THUNDER KETTLE 60 OZ WITH POWER DUMP

## GAS GIANT – PEDESTAL-STYLE KETTLE

**ANOTHER INDUSTRY FIRST FROM CRETORS!** This high performance GT kettle with power dump has a unique infrared burner that is energy efficient, environmentally friendly and offers faster kettle heating cycles.

### IMPROVEMENTS

- Power Dump system reduces labor costs
- Attached green beacon light signals dump action as the kettle dumps
- Wear and tear on parts reduced
- Remote control switch can be mounted on table for easy operation
- BTUs are reduced up to 30% from standard burner
- Fuel usage is reduced up to 30% from standard burner
- Electronic ignition automatically lights when temperature controller calls for heat
- No standing pilot light to blow out and use fuel
- Improved popping cycle
- Infrared flame is stronger and protected making it more wind resistant
- Better access to electrical parts (cabinet)
- Patent pending design



### STANDARD FEATURES

- Propane or natural gas
- Electric direct drive motor
- Requires small amount of electrical power (contact your Cretors representative for further details)
- Lighted rocker switches
- Easy-to-read controls
- Exhaust vent located on back of kettle
- Digital readout ensures accurate temperature settings and readings
- A safety off switch automatically turns off burner flame when the kettle is lifted for dumping. The flame automatically relights when the kettle is placed back into the cooking position
- Cycling pilot light with digital temperature controller



# GAS GIANT THUNDER KETTLE 60 OZ WITH POWER DUMP PEDESTAL-STYLE POPPER NORTH AMERICA

MACHINE	KETTLE		ELECTRICAL				MACHINE DIMENSIONS INCHES			SHIP DIMENSIONS INCHES			SHIP WEIGHT
	SIZE	SERVINGS*	VOLTAGE	WATTS	BTU	NEMA	LENGTH	WIDTH	HEIGHT	LENGTH	WIDTH	HEIGHT	lb
Gas Giant Thunder Kettle With Power Dump	60 oz	1200	120V/60HZ	160	37,000	5-15	22.50	22.00	33.00	-	-	-	-

# GAS GIANT THUNDER KETTLE 60 OZ WITH POWER DUMP PEDESTAL-STYLE POPPER EXPORT

MACHINE	KETTLE		ELECTRICAL				MACHINE DIMENSIONS CENTIMETERS			SHIP DIMENSIONS CENTIMETERS			SHIP WEIGHT
	SIZE	SERVINGS*	VOLTAGE	WATTS	BTU		LENGTH	WIDTH	HEIGHT	LENGTH	WIDTH	HEIGHT	kg
Gas Giant Thunder Kettle With Power Dump	60 oz	1200	230V/50HZ	160	37,000		57.20	56.10	85.50	-	-	-	-

\* 1 oz servings per hour

• Contact Cretors for details





# Gas Giant Thunder Kettle 60 Oz

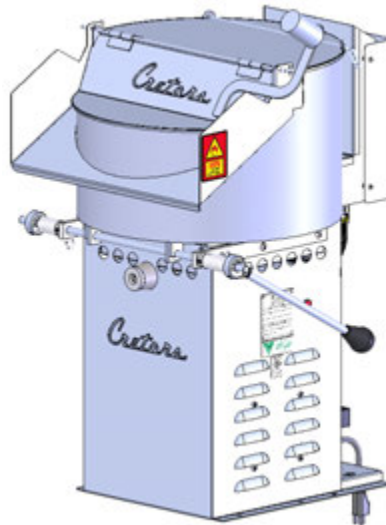

Part Number	Voltage	Wattage	BTU	NEMA Plug	Dimensions
GT60 (NG OR Propane)	120V / 60HZ 230V / 50HZ	160 WATTS	37,500 (NG) 38,500 (Propane)	5-15 (US & Canada)	SEE BELOW

